

# meaden

---

## Slitter & Perforator Wheels

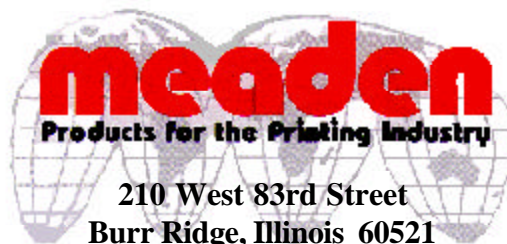
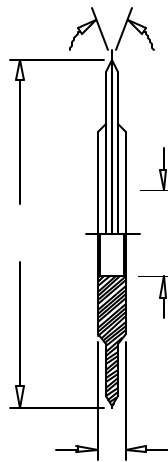

210 West 83rd Street  
Burr Ridge, Illinois 60521  
Telephone: 630/655-0888  
FAX: 630/655-3012  
[www.meadenprinting.com](http://www.meadenprinting.com)

# Table of Contents

Product	Page
Ordering information .....	4-6
Press wheels (crush) .....	8-49
Core cutter blades .....	51-54
Trimmer blades .....	55-60
Dished blades .....	61-62
Collator blades .....	63-68
Wheel holders .....	69-70

---

---

## **Meaden Return Policy**

Stocked, standard catalog items may be returned within 30 days of invoice, subject to a 10% restocking charge. All returns must be in resellable condition and in their original packaging. Open packages are not returnable. An Authorized Return Form (ARF) number must be issued before a return will be accepted. Credits will be issued only after the approval of Quality Control. Any product that does not meet these requirements will be returned to the customer.

No specials of any kind are returnable! Specials made per your instructions are not stock items, and not returnable. Examples of specials are irregular shaped punches and dies, and all special cut perforator wheels.

---

**ALL PRICES SUBJECT TO CHANGE WITHOUT NOTICE!**

---

**meaden** wheels are made with the same high quality materials and workmanship as our punches and dies, long recognized as the highest quality made.

Although our part numbering system is designed to make ordering easy, it is helpful to identify the press or piece of equipment the wheel is being used with.

## Slitter Wheels:

are designated with a -0 after the part number to indicate that there are no teeth on the wheel.

For example: 14936-0

Indicates slitter wheel, no teeth

Indicates basic wheel shape

is a slitter wheel .

## Perforating Wheels:

are specified with three number groups separated by dashes. The first group identifies the wheel blank used to make the perforator wheel. The second number group is the amount of cuts per inch that the wheel will produce. The third section is the width of the tie or space between teeth.

For example: 14936-4-030

Indicates number of cuts per inch

Indicates width of ties

Indicates basic wheel shape

describes the basic wheel-14936, the number of cuts per inch desired-4, and the size of the ties between the cuts-.030". The standard tie used is 0.030" wide. Any number of other tie widths are available on request and are easily specified using the order code.

For example: 14936 -6-040

Indicates number of cuts per inch

Indicates width of ties

Indicates basic wheel shape

is the perforating wheel -14936, with 6 cuts per inch and 0.040" ties between cuts.

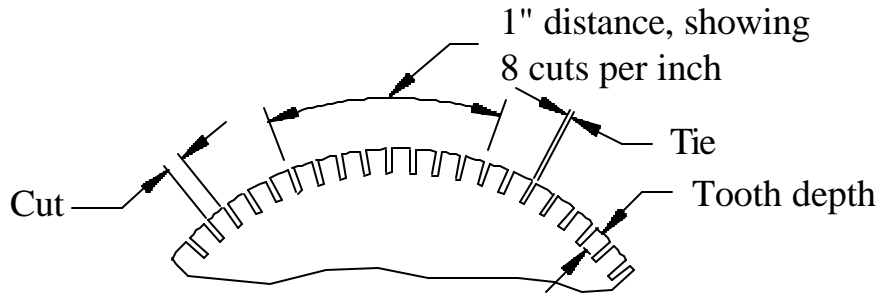

## Hardness of standard wheels:

All **meaden** wheels are made from premium quality toolsteel. The normal hardness varies between 59 and 61 Rc, one exception being part #14933 which is for use with softer or worn anvils.

Standard tie width is .030"

## Other ties available:

We provide a number of different ties under .060" wide at no extra charge. For ties greater than .060" wide, add 15% to the cost of the wheel. Other ties available are:

.020", .023", .027", .032", .034", .036", .040", .045", .050", .054" and .060"

Note! Different tie widths are not combinable for quantity pricing.

GENERAL TOOTH DEPTHS		
TEETH PER WHEEL		DEPTH
1- 55	2.000" wheels	5/32"
56- 66		1/8"
67- Over		1/16"
1- 70	2.625" wheels	5/32"
71- 90		1/8"
90- Over		1/16"
1- 85	3.000" + wheels	5/32"
86- 110		1/8"
111- Over		1/16"

Tooth depth is reduced as the number of teeth per wheel increases to prevent breaking the teeth on impact with the anvil.

Most of the wheels listed can be found on a variety of brands and types of equipment. We have indicated common uses by brand of machine where ever possible. However, equipment manufacturers have changed their specifications over the years, and some equipment has been modified in the field to use different wheels than originally specified. With that in mind, the wheels in this section are arranged according to size. The sorting order criteria being:

1. outside diameter
2. inside diameter
3. thickness

The standard tip radius for **meaden** wheels is .003-.005" unless otherwise noted. In many cases, a "sharp" version is available, which would have a tip radius of .0015-.0025". Find the standard wheel based on dimensions. If there is a sharp version available, the corresponding part number will be shown above the wheel drawing. Use the sharp number to order.

When ordering replacement wheels for 1/2inch wide "pancake" style pneumatic holders (Meaden/Burris/Dienes), the corresponding wheel will be either Meaden #19721 for 19 mm (.748") I.D., or Meaden #14929 for 22 mm I.D. For the Lisa brand holder the correct wheel is Meaden #19457

# Table of Contents

Press	Page	Press	Page
A.T.F.	31	Lisa	44
ADT	20	Morgan	19
Akira	14	Muller Martini	37, 46, 48, 49
Ashton	22, 36	New Era	23
Baldwin-Greg	32	PCM	16
Cameron	40, 42	RDP-Marathon	22, 36
Codimag	21, 40	Rotatek	18, 28, 38, 40
Count	9	Rotometrics RD Scorer	11, 12
Didde Web	24, 25	Ryhobi	14
Doverstar	8	Sanden	22, 36
Drent	18, 21	Schober	47
Dusenbery	39	Schriber/Harris	28
ECH-Will	21	Seailles & Tison	26
Edelmann Formall	28, 40	Stevens	40, 42, 43
Giebeler	18, 21, 38, 40	Superweb	24
Goebel	33, 45	Taiyo Kikai	34
Grapha Muller	18, 38	Timsons	15
Graphic Whizard	10	Uarco	17
Hamilton	40, 42, 43	Ukita	13
Heidelberg	8, 10	Western Gear	27
Kidder	41	Witt	30
Ko Pack	8		

## Pricing Information 19927

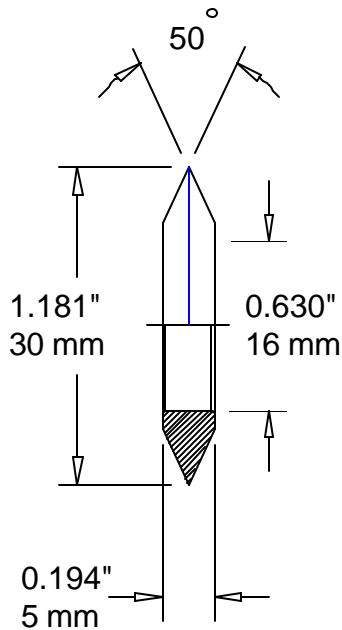

Part Number	Cuts / inch	Teeth / wheel
19927-0	0	0
19927-2	2	7
19927-3	3	11
19927-4	4	15
19927-5	5	19
19927-6	6	22
19927-7	7	26
19927-8	8	30
19927-10	10	37
19927-12	12	45
19927-16	16	59

### meaden mini perfs

19927-3010	30	110
19927-4510	45	166
19927-5010	50	184
19927-6610	66	244
19927-7210	72	266
19927-3030	30	110
19927-4530	45	166
19927-5030	50	184
19927-6630	66	244
19927-7230	72	266

**DOVERSTAR  
KO PACK  
HEIDELBERG**

**bearing 634-Z  
\$8.00 each**

No charges for marking  
Other ties available at no charge up to .060" wide  
Any combination of cuts and ties available on request.

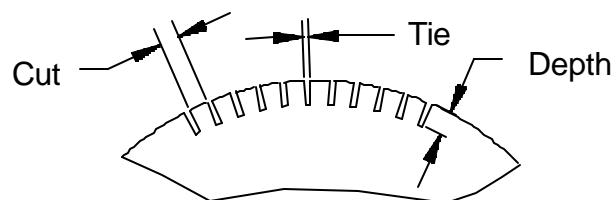

**meaden**

## Pricing Information 32069

**Cutting Edge  
has tip radius  
of .002"**

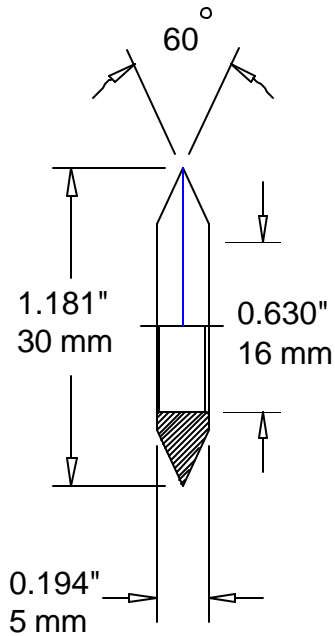

**COUNT**

Part Number	Cuts / inch	Teeth / wheel
32069-0	0	0
32069-2	2	7
32069-3	3	11
32069-4	4	15
32069-5	5	19
32069-6	6	22
32069-7	7	26
32069-8	8	30
32069-10	10	37
32069-12	12	45
32069-16	16	59

**meaden mini perfs**

32069-3010	30	110
32069-4510	45	166
32069-5010	50	184
32069-6610	66	244
32069-7210	72	266
32069-3030	30	110
32069-4530	45	166
32069-5030	50	184
32069-6630	66	244
32069-7230	72	266

No charges for marking

Other ties available at no charge up to .060" wide

Any combination of cuts and ties available on request.

**bearing 634-Z  
\$8.00 each**

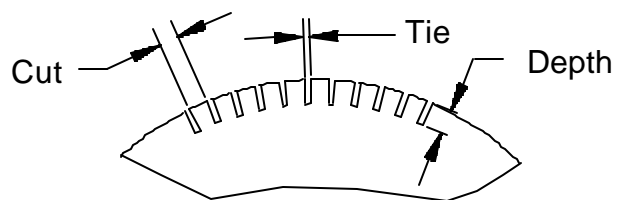

## Pricing Information 18494

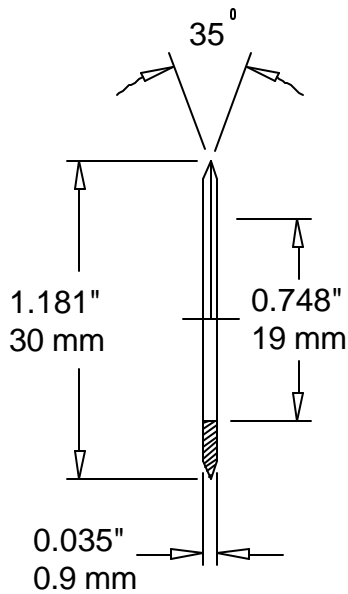

Part Number	Cuts / inch	Teeth / wheel
18494-0	0	0
18494-2	2	7
18494-3	3	11
18494-4	4	15
18494-5	5	19
18494-6	6	22
18494-7	7	26
18494-8	8	30
18494-10	10	37
18494-12	12	45
18494-16	16	59

### meaden mini perfs

18494-3010	30	110
18494-4510	45	166
18494-5010	50	184
18494-6610	66	244
18494-7210	72	266
18494-3030	30	110
18494-4530	45	166
18494-5030	50	184
18494-6630	66	244
18494-7230	72	266

## HEIDELBERG GRAPHIC WHIZARD

No charges for marking  
 Other ties available at no charge up to .060" wide  
 Any combination of cuts and ties available on request.

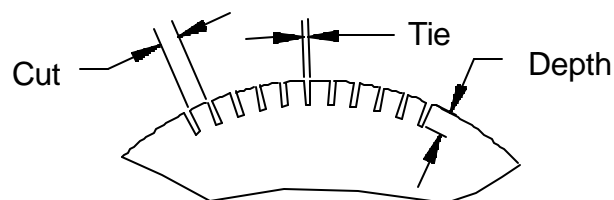

## Pricing Information 30275

**This blade has a radiused tip for crush slitting.**

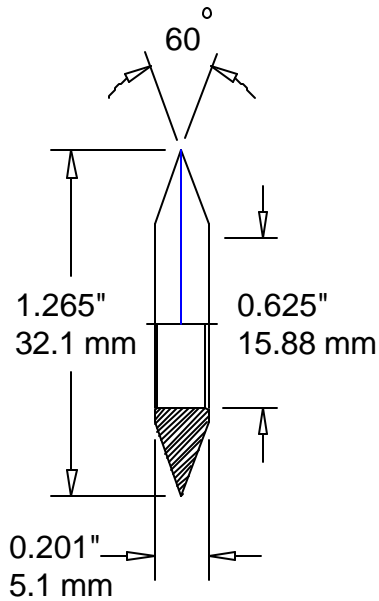

**Use number 31746 for face or liner slitting.**

**ROTO-METRICS**  
RD SCORER

**bearing 30987**  
**\$8.00 each**

Part Number	Cuts / inch	Teeth / wheel
30275-0	0	0
30275-2	2	8
30275-3	3	12
30275-4	4	16
30275-5	5	20
30275-6	6	24
30275-7	7	28
30275-8	8	32
30275-10	10	40
30275-12	12	48
30275-16	16	64

**meaden mini perfs**

30275-3010	30	118
30275-4510	45	182
30275-5010	50	199
30275-6610	66	266
30275-7210	72	286
30275-3030	30	118
30275-4530	45	182
30275-5030	50	199
30275-6630	66	266
30275-7230	72	286

No charges for marking

Other ties available at no charge up to .060" wide

Any combination of cuts and ties available on request.

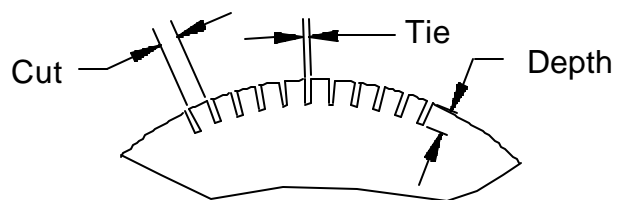

## Pricing Information 31746

**This blade has a true-sharp tip for face or liner slitting.**

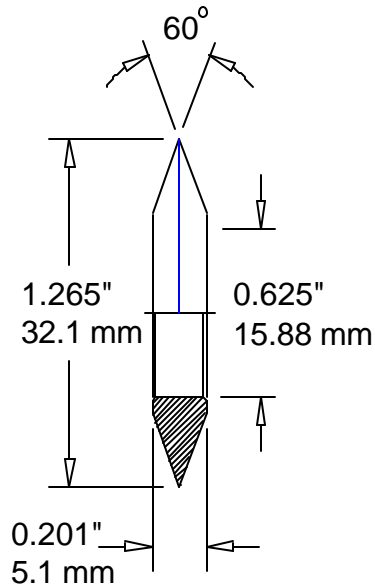

**Use number 30275 for crush slitting.**

**ROTO-METRICS**  
RD SCORER

**bearing 30987**  
**\$8.00 each**

Part Number	Cuts / inch	Teeth / wheel
31746-0	0	0
31746-2	2	8
31746-3	3	12
31746-4	4	16
31746-5	5	20
31746-6	6	24
31746-7	7	28
31746-8	8	32
31746-10	10	40
31746-12	12	48
31746-16	16	64

### meaden mini perfs

31746-3010	30	118
31746-4510	45	182
31746-5010	50	199
31746-6610	66	266
31746-7210	72	286
31746-3030	30	118
31746-4530	45	182
31746-5030	50	199
31746-6630	66	266
31746-7230	72	286

No charges for marking

Other ties available at no charge up to .060" wide  
Any combination of cuts and ties available on request.

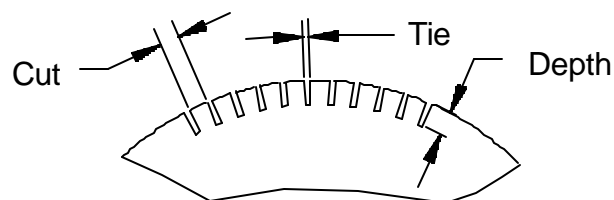

**meaden**

## Pricing Information 19776

**This blade has a true-sharp tip**

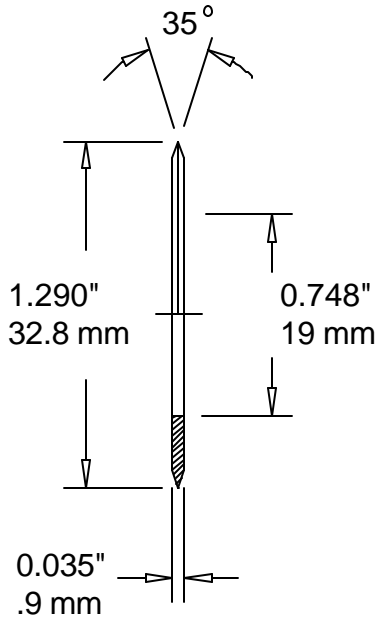

Part Number	Cuts / inch	Teeth / wheel
19776-0	0	0
19776-2	2	8
19776-3	3	12
19776-4	4	16
19776-5	5	20
19776-6	6	24
19776-7	7	28
19776-8	8	32
19776-10	10	40
19776-12	12	48
19776-16	16	63

**meaden mini perfs**

19776-3010	30	120
19776-4510	45	182
19776-5010	50	202
19776-6610	66	266
19776-7210	72	290
19776-3030	30	120
19776-4530	45	182
19776-5030	50	202
19776-6630	66	266
19776-7230	72	290

**UKITA**

No charges for marking

Other ties available at no charge up to .060" wide

Any combination of cuts and ties available on request.

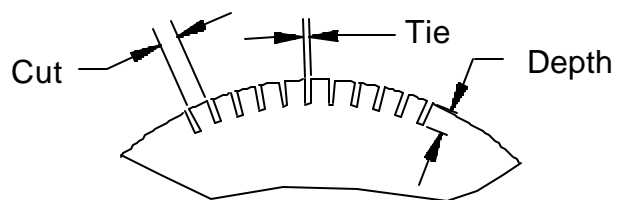

**meaden**

## Product Information 19746

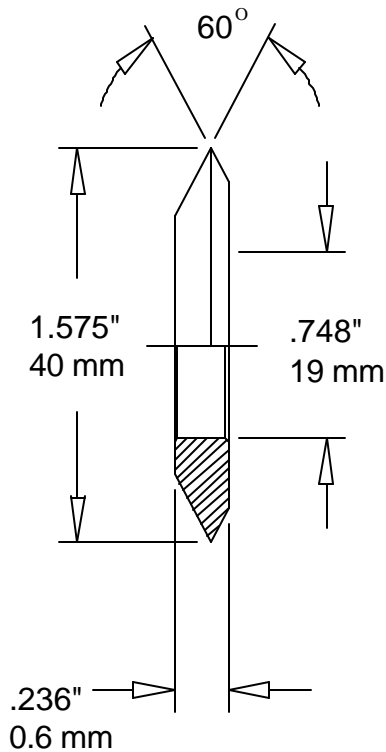

**AKIRA  
RYHOBI**

**bearing C-96-PP  
\$4.00 each**

Part Number	Cuts / inch	Teeth / wheel
19746-0	0	0
19746-2	2	10
19746-3	3	15
19746-4	4	20
19746-5	5	25
19746-6	6	30
19746-7	7	35
19746-8	8	40
19746-10	10	50
19746-12	12	59
19746-16	16	79

19746-3010	30	148
19746-4510	45	222
19746-5010	50	246
19746-6610	66	326
19746-7210	72	356
19746-3030	30	148
19746-4530	45	222
19746-5030	50	246
19746-6630	66	326
19746-7230	72	356

No charges for marking

Other ties available at no charge up to .060" wide  
Any combination of cuts and ties available on request.

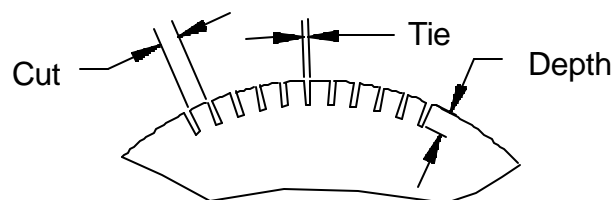

**meaden**

## Pricing Information 17148

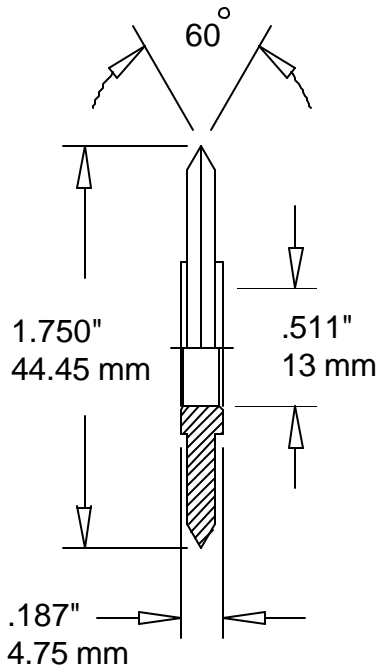

### TIMSONS

Part Number	Cuts / inch	Teeth / wheel
17148-0	0	0
17148-2	2	11
17148-3	3	17
17148-4	4	22
17148-5	5	28
17148-6	6	33
17148-7	7	39
17148-8	8	44
17148-10	10	55
17148-12	12	66
17148-16	16	88

### meaden mini perfs

17148-3010	30	164
17148-4510	45	246
17148-5010	50	274
17148-6610	66	362
17148-7210	72	394
17148-3030	30	164
17148-4530	45	246
17148-5030	50	274
17148-6630	66	362
17148-7230	72	394

No charges for marking

Other ties available at no charge up to .060" wide

Any combination of cuts and ties available on request.

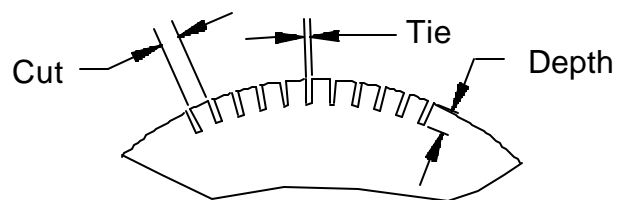

## Pricing Information 17997

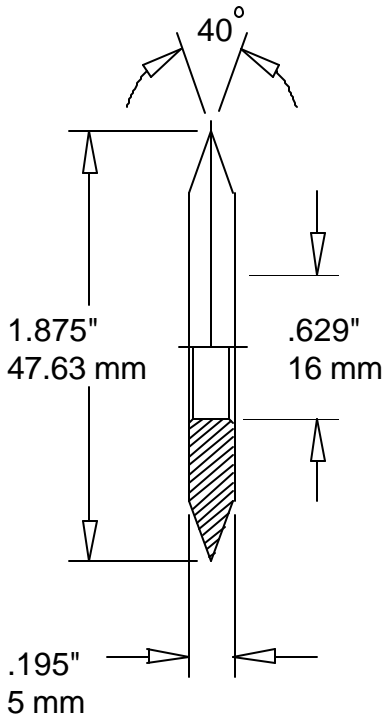

**P C M**

Part Number	Cuts / inch	Teeth / wheel
17997-0	0	0
17997-2	2	12
17997-3	3	18
17997-4	4	24
17997-5	5	29
17997-6	6	35
17997-7	7	41
17997-8	8	47
17997-10	10	59
17997-12	12	71
17997-16	16	94

### meaden mini perfs

17997-3010	30	176
17997-4510	45	264
17997-5010	50	294
17997-6610	66	388
17997-7210	72	424
17997-3030	30	176
17997-4530	45	264
17997-5030	50	294
17997-6630	66	388
17997-7230	72	424

No charges for marking

Other ties available at no charge up to .060" wide

Any combination of cuts and ties available on request.

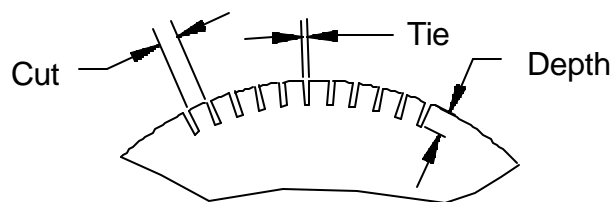

**meaden**

## Pricing Information 31302

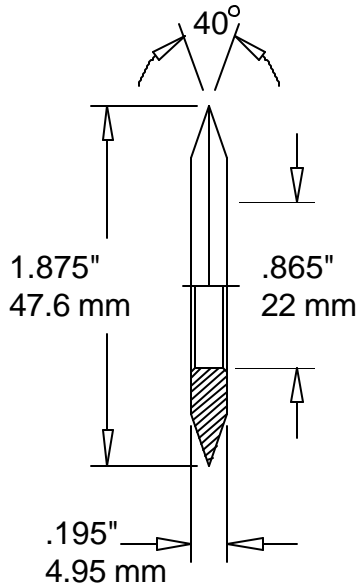

Part Number	Cuts / inch	Teeth / wheel
31302-0	0	0
31302-2	2	12
31302-3	3	18
31302-4	4	24
31302-5	5	29
31302-6	6	35
31302-7	7	41
31302-8	8	47
31302-10	10	59
31302-12	12	71
31302-16	16	94

### meaden mini perfs

31302-3010	30	176
31302-4510	45	264
31302-5010	50	294
31302-6610	66	388
31302-7210	72	424
31302-3030	30	176
31302-4530	45	264
31302-5030	50	294
31302-6630	66	388
31302-7230	72	424

**UARCO**

No charges for marking

Other ties available at no charge up to .060" wide

Any combination of cuts and ties available on request.

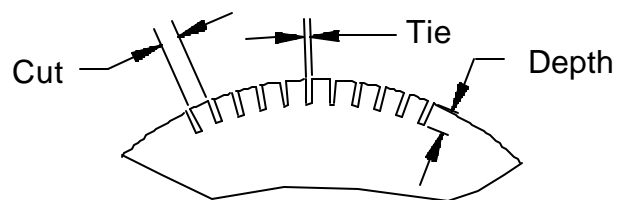

**meaden**

## Pricing Information 15706

sharp=21160

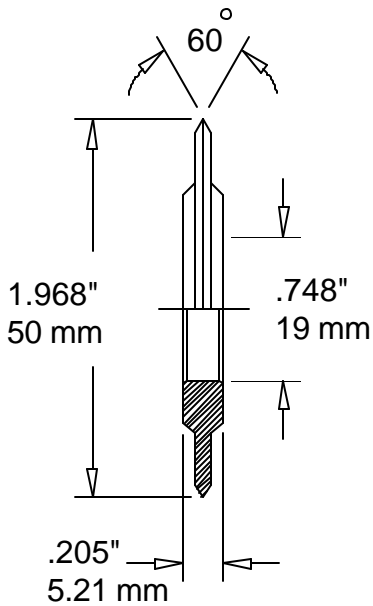

**DRENT  
GIEBELER  
GRAPHA  
ROTATEK**

Part Number	Cuts / inch	Teeth / wheel
15706-0	0	0
15706-2	2	12
15706-3	3	19
15706-4	4	25
15706-5	5	31
15706-6	6	37
15706-7	7	43
15706-8	8	50
15706-10	10	62
15706-12	12	74
15706-16	16	99

### meaden mini perfs

15706-3010	30	186
15706-4510	45	278
15706-5010	50	309
15706-6610	66	408
15706-7210	72	445
15706-3030	30	186
15706-4530	45	278
15706-5030	50	306
15706-6630	66	408
15706-7230	72	445

No charges for marking

Other ties available at no charge up to .060" wide

Any combination of cuts and ties available on request.

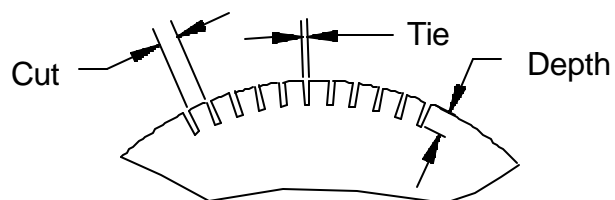

**meaden**

## Pricing Information 17767

**sharp=21158**

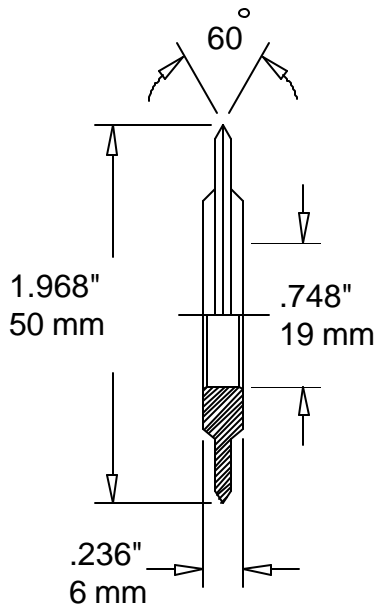

Part Number	Cuts / inch	Teeth / wheel
17767-0	0	0
17767-2	2	12
17767-3	3	19
17767-4	4	25
17767-5	5	31
17767-6	6	37
17767-7	7	43
17767-8	8	50
17767-10	10	62
17767-12	12	74
17767-16	16	99

**meaden mini perfs**

17767-3010	30	186
17767-4510	45	278
17767-5010	50	309
17767-6610	66	408
17767-7210	72	445
17767-3030	30	186
17767-4530	45	278
17767-5030	50	309
17767-6630	66	408
17767-7230	72	445

**MORGAN**

No charges for marking

Other ties available at no charge up to .060" wide

Any combination of cuts and ties available on request.

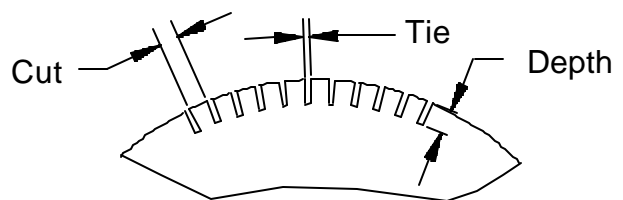

**meaden**

## Pricing Information 32011

**This blade has a true-sharp tip for face or liner slitting.**

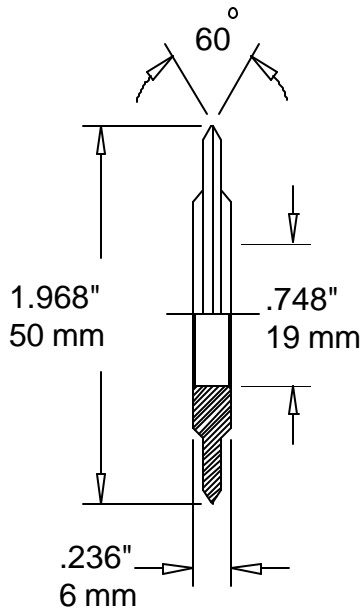

Part Number	Cuts / inch	Teeth / wheel
32011-0	0	0
32011-2	2	12
32011-3	3	19
32011-4	4	25
32011-5	5	31
32011-6	6	37
32011-7	7	43
32011-8	8	50
32011-10	10	62
32011-12	12	74
32011-16	16	99

### meaden mini perfs

32011-3010	30	186
32011-4510	45	278
32011-5010	50	309
32011-6610	66	408
32011-7210	72	445
32011-3030	30	186
32011-4530	45	278
32011-5030	50	309
32011-6630	66	408
32011-7230	72	445

**AMERICAN DIE  
TECHNOLOGY  
ADVANCED  
MULTI-SCORER**

No charges for marking

Other ties available at no charge up to .060" wide  
Any combination of cuts and ties available on request.

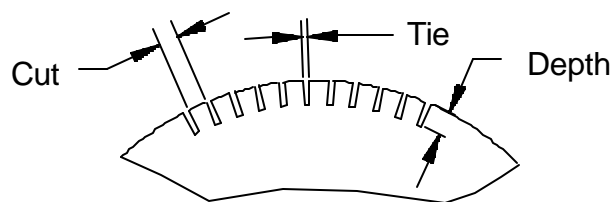

**meaden**

## Pricing Information 15425

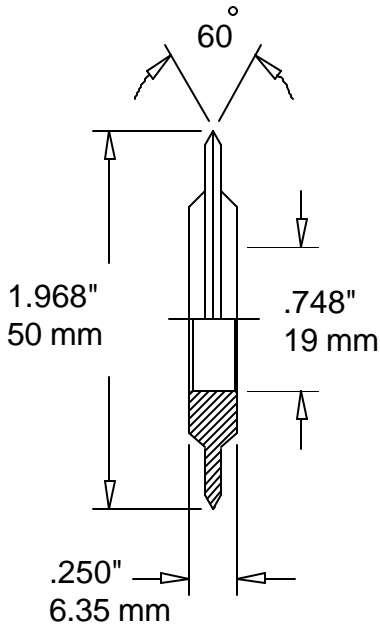

**DRENT  
CODIMAG  
GIEBELER  
ECH-WILL**

**bearing C-96-PP  
\$4.00 each**

Part Number	Cuts / inch	Teeth / wheel
15425-0	0	0
15425-2	2	12
15425-3	3	19
15425-4	4	25
15425-5	5	31
15425-6	6	37
15425-7	7	43
15425-8	8	50
15425-10	10	62
15425-12	12	74
15425-16	16	99

**meaden mini perfs**

15425-3010	30	186
15425-4510	45	278
15425-5010	50	309
15425-6610	66	408
15425-7210	72	445
15425-3030	30	186
15425-4530	45	278
15425-5030	50	309
15425-6630	66	408
15425-7230	72	445

No charges for marking

Other ties available at no charge up to .060" wide

Any combination of cuts and ties available on request.

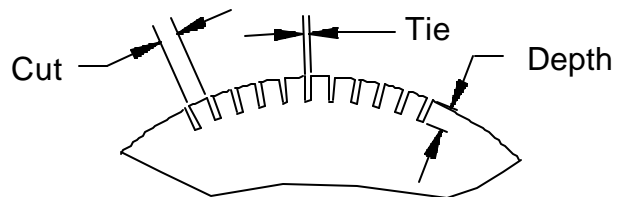

## Pricing Information 14927

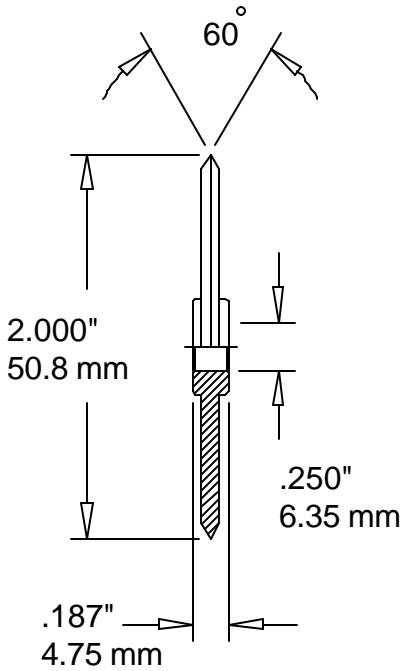

Part Number	Cuts / inch	Teeth / wheel
14927-0	0	0
14927-2	2	13
14927-3	3	19
14927-4	4	25
14927-5	5	31
14927-6	6	38
14927-7	7	44
14927-8	8	50
14927-10	10	63
14927-12	12	75
14927-16	16	100

### meaden mini perfs

14927-3010	30	188
14927-4510	45	282
14927-5010	50	314
14927-6610	66	414
14927-7210	72	452
14927-3030	30	188
14927-4530	45	282
14927-5030	50	314
14927-6630	66	414
14927-7230	72	452

**ASHTON  
SANDEN  
RDP-MARATHON**

No charges for marking

Other ties available at no charge up to .060" wide

Any combination of cuts and ties available on request.

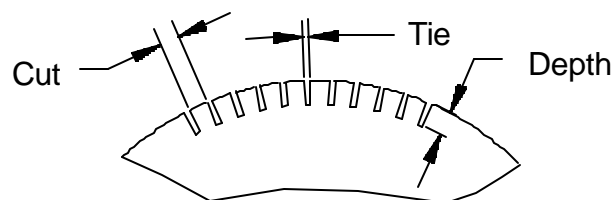

**meaden**

## Pricing Information 14935

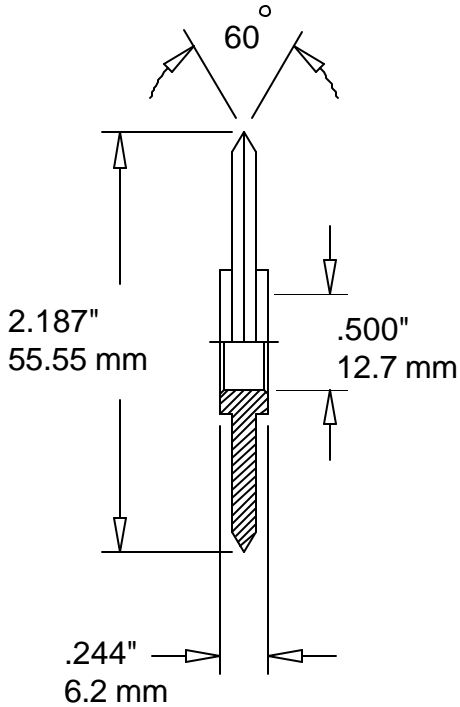

### NEW ERA

Part Number	Cuts / inch	Teeth / wheel
14935-0	0	0
14935-2	2	14
14935-3	3	21
14935-4	4	27
14935-5	5	34
14935-6	6	41
14935-7	7	48
14935-8	8	55
14935-10	10	69
14935-12	12	82
14935-16	16	110

### meaden mini perfs

14935-3010	30	206
14935-4510	45	308
14935-5010	50	342
14935-6610	66	452
14935-7210	72	494
14935-3030	30	206
14935-4530	45	308
14935-5030	50	342
14935-6630	66	452
14935-7230	72	494

No charges for marking

Other ties available at no charge up to .060" wide

Any combination of cuts and ties available on request.

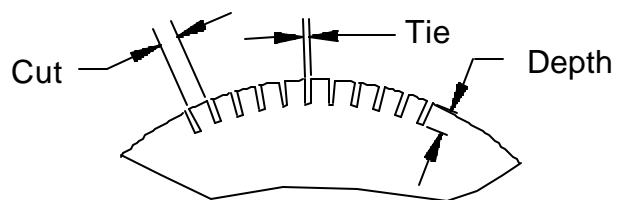

Pricing Information 14931

sharp=21155

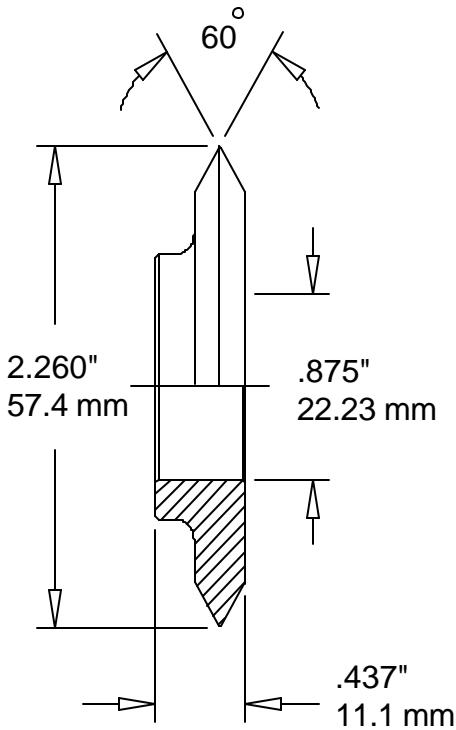

Part Number	Cuts / inch	Teeth / wheel
14931-0	0	0
14931-2	2	14
14931-3	3	21
14931-4	4	28
14931-5	5	35
14931-6	6	42
14931-7	7	50
14931-8	8	57
14931-10	10	71
14931-12	12	85
14931-16	16	113

**meaden mini perfs**

14931-3010	30	212
14931-4510	45	320
14931-5010	50	354
14931-6610	66	468
14931-7210	72	510
14931-3030	30	212
14931-4530	45	320
14931-5030	50	354
14931-6630	66	468
14931-7230	72	510

**DIDDE WEB  
SUPERWEB**

bearing R-6  
\$6.00 each

No charges for marking  
Other ties available at no charge up to .060" wide  
Any combination of cuts and ties available on request.

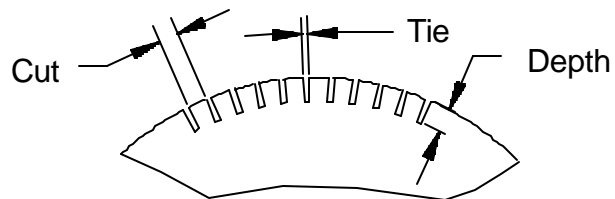

## Pricing Information 31108

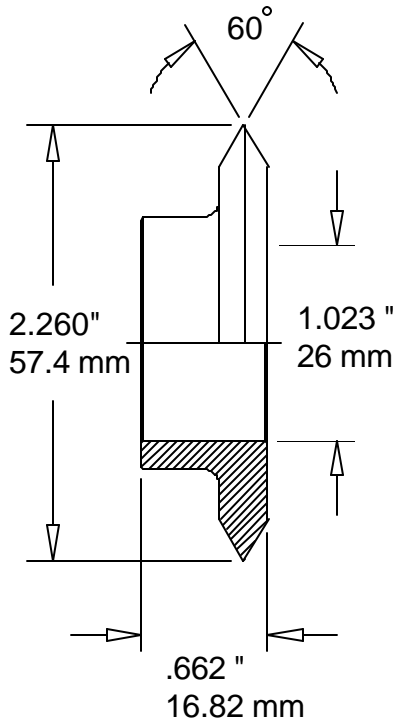

Part Number	Cuts / inch	Teeth / wheel
31108-0	0	0
31108-2	2	14
31108-3	3	21
31108-4	4	28
31108-5	5	35
31108-6	6	42
31108-7	7	50
31108-8	8	57
31108-10	10	71
31108-12	12	85
31108-16	16	113

### meaden mini perms

31108-3010	30	212
31108-4510	45	320
31108-5010	50	354
31108-6610	66	468
31108-7210	72	510
31108-3030	30	212
31108-4530	45	320
31108-5030	50	354
31108-6630	66	468
31108-7230	72	510

## DIDDE WEB

bearing 31112  
\$6.00 each

No charges for marking

Other ties available at no charge up to .060" wide

Any combination of cuts and ties available on request.

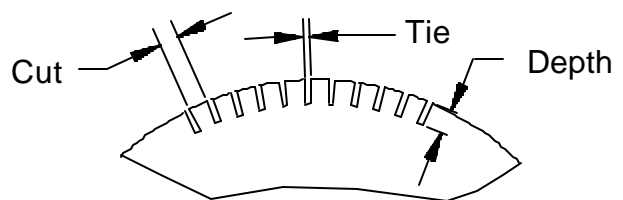

## Pricing Information 18701

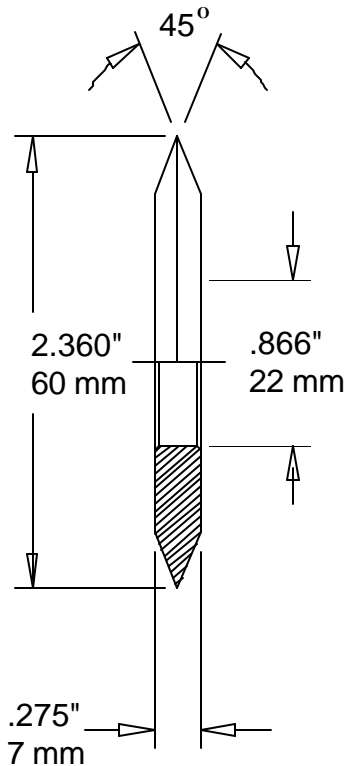

Part Number	Cuts / inch	Teeth / wheel
18701-0	0	0
18701-2	2	15
18701-3	3	22
18701-4	4	30
18701-5	5	37
18701-6	6	45
18701-7	7	52
18701-8	8	59
18701-10	10	74
18701-12	12	89
18701-16	16	119

### meaden mini perfs

18701-3010	30	222
18701-4510	45	332
18701-5010	50	370
18701-6610	66	488
18701-7210	72	532
18701-3030	30	222
18701-4530	45	332
18701-5030	50	370
18701-6630	66	488
18701-7230	72	532

## SEAILLES & TISON

bearing X-117  
\$8.00 each

No charges for marking  
Other ties available at no charge up to .060" wide  
Any combination of cuts and ties available on request.

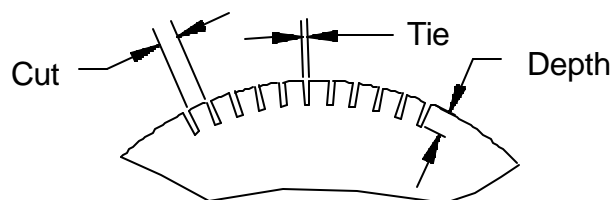

## Pricing Information 14937

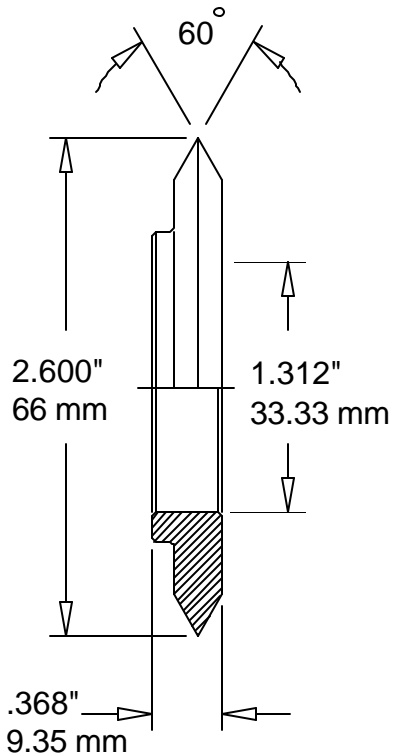

Part Number	Cuts / inch	Teeth / wheel
14937-0	0	0
14937-2	2	16
14937-3	3	25
14937-4	4	33
14937-5	5	41
14937-6	6	49
14937-7	7	57
14937-8	8	65
14937-10	10	82
14937-12	12	98
14937-16	16	131

### meaden mini perfs

14937-3010	30	246
14937-4510	45	366
14937-5010	50	408
14937-6610	66	538
14937-7210	72	588
14937-3030	30	246
14937-4530	45	366
14937-5030	50	408
14937-6630	66	538
14937-7230	72	588

## WESTERN GEAR

bearing LS-5  
\$7.40 each

No charges for marking

Other ties available at no charge up to .060" wide  
Any combination of cuts and ties available on request.

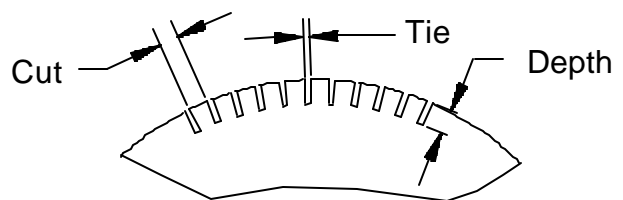

## Pricing Information 14936

### sharp=30100

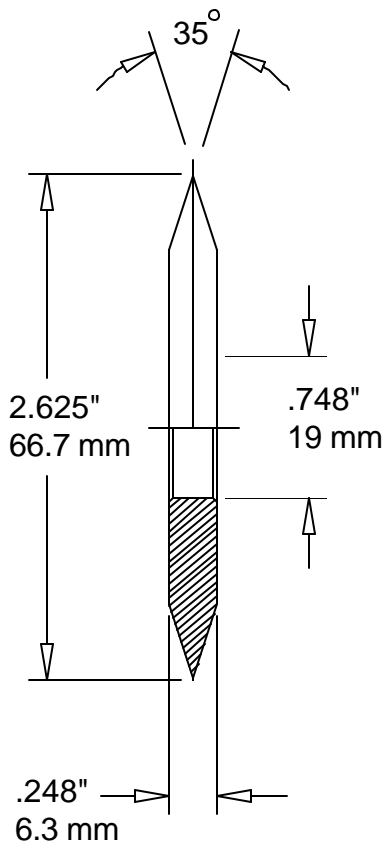

**SCHRIBER/  
HARRIS  
EDELMANN  
ROTATEK**

**bearing C-96-PP  
\$4.00 each**

Part Number	Cuts / inch	Teeth / wheel
14936-0	0	0
14936-2	2	16
14936-3	3	25
14936-4	4	33
14936-5	5	41
14936-6	6	49
14936-7	7	58
14936-8	8	66
14936-10	10	82
14936-12	12	99
14936-16	16	132

### meaden mini perfs

14936-3010	30	248
14936-4510	45	370
14936-5010	50	412
14936-6610	66	544
14936-7210	72	594
14936-3030	30	248
14936-4530	45	370
14936-5030	50	412
14936-6630	66	544
14936-7230	72	594

No charges for marking

Other ties available at no charge up to .060" wide  
Any combination of cuts and ties available on request.

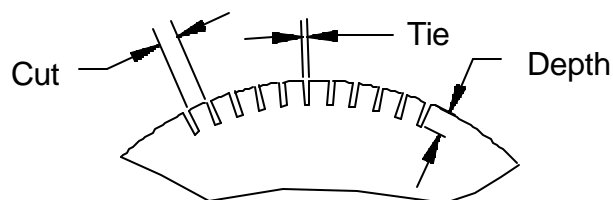

**meaden**

## Pricing Information 30033

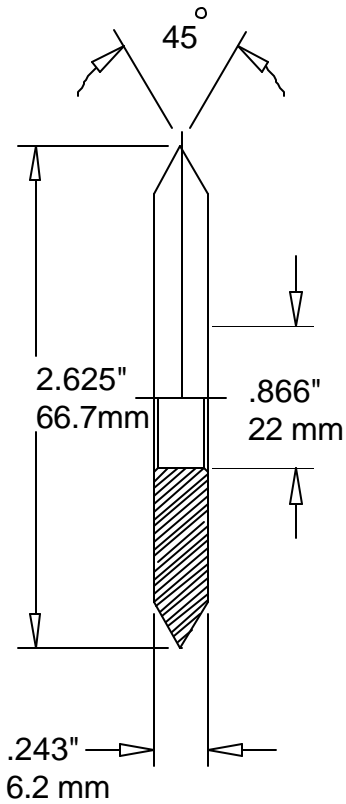

Part Number	Cuts / inch	Teeth / wheel
30033-0	0	0
30033-2	2	17
30033-3	3	25
30033-4	4	33
30033-5	5	41
30033-6	6	50
30033-7	7	58
30033-8	8	66
30033-10	10	83
30033-12	12	99
30033-16	16	132

### meaden mini perfs

30033-3010	30	246
30033-4510	45	370
30033-5010	50	412
30033-6610	66	544
30033-7210	72	592
30033-3030	30	246
30033-4530	45	370
30033-5030	50	412
30033-6630	66	544
30033-7230	72	592

**Note: This wheel is 55 - 57 Rc to prevent anvil damage**

No charges for marking

Other ties available at no charge up to .060" wide

Any combination of cuts and ties available on request.

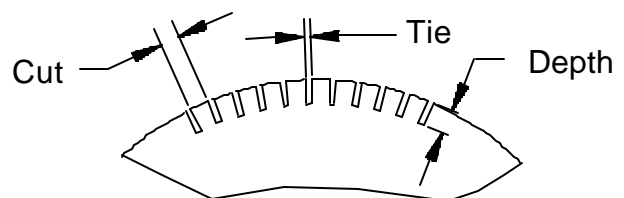

Pricing Information 14938

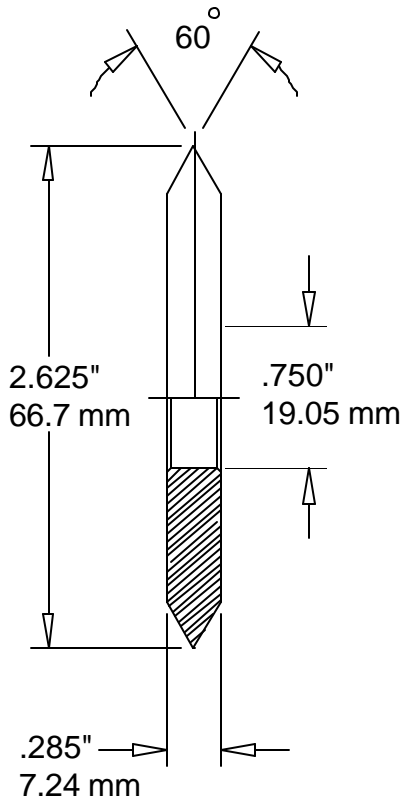

**WITT**

Part Number	Cuts / inch	Teeth / wheel
14938-0	0	0
14938-2	2	17
14938-3	3	25
14938-4	4	33
14938-5	5	41
14938-6	6	50
14938-7	7	58
14938-8	8	66
14938-10	10	83
14938-12	12	99
14938-16	16	132

**meaden mini perfs**

14938-3010	30	246
14938-4510	45	370
14938-5010	50	412
14938-6610	66	544
14938-7210	72	592
14938-3030	30	246
14938-4530	45	370
14938-5030	50	412
14938-6630	66	544
14938-7230	72	592

No charges for marking  
 Other ties available at no charge up to .060" wide  
 Any combination of cuts and ties available on request.

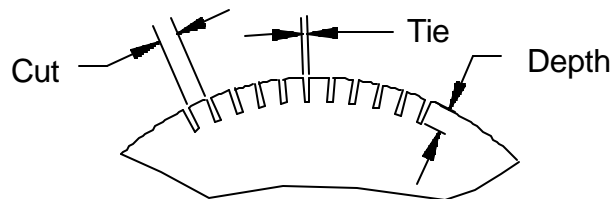

## Pricing Information 14928

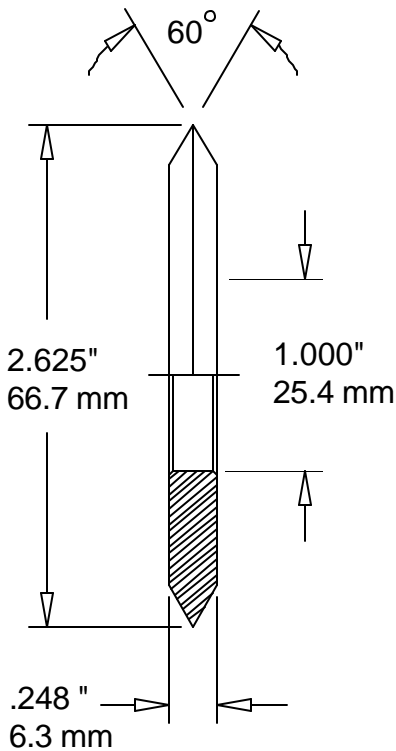

**A.T.F.**

Part Number	Cuts / inch	Teeth / wheel
14928-0	0	0
14928-2	2	17
14928-3	3	25
14928-4	4	33
14928-5	5	41
14928-6	6	50
14928-7	7	58
14928-8	8	66
14928-10	10	83
14928-12	12	99
14928-16	16	132

**meaden mini perfs**

14928-3010	30	246
14928-4510	45	370
14928-5010	50	412
14928-6610	66	544
14928-7210	72	592
14928-3030	30	246
14928-4530	45	370
14928-5030	50	412
14928-6630	66	544
14928-7230	72	592

No charges for marking

Other ties available at no charge up to .060" wide

Any combination of cuts and ties available on request.

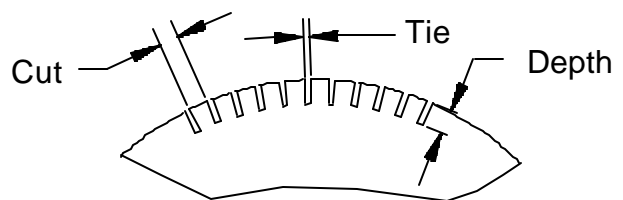

**meaden**

# Pricing Information 31338

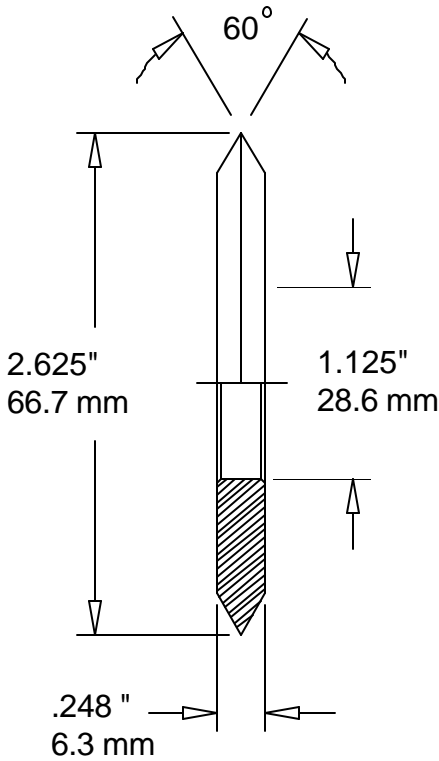

Part Number	Cuts / inch	Teeth / wheel
31338-0	0	0
31338-2	2	16
31338-3	3	24
31338-4	4	31
31338-5	5	39
31338-6	6	47
31338-7	7	55
31338-8	8	63
31338-10	10	79
31338-12	12	94
31338-16	16	126

**meaden mini perfs**

31338-3010	30	236
31338-4510	45	353
31338-5010	50	393
31338-6610	66	518
31338-7210	72	565
31338-3030	30	236
31338-4530	45	353
31338-5030	50	393
31338-6630	66	518
31338-7230	72	565

## BALDWIN-GREGG

No charges for marking  
 Other ties available at no charge up to .060" wide  
 Any combination of cuts and ties available on request.

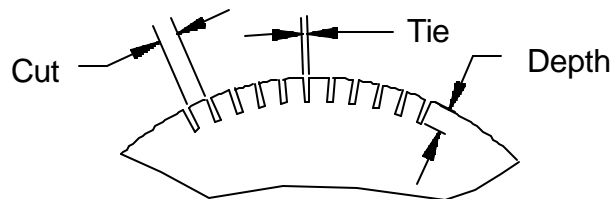

## Pricing Information 16290

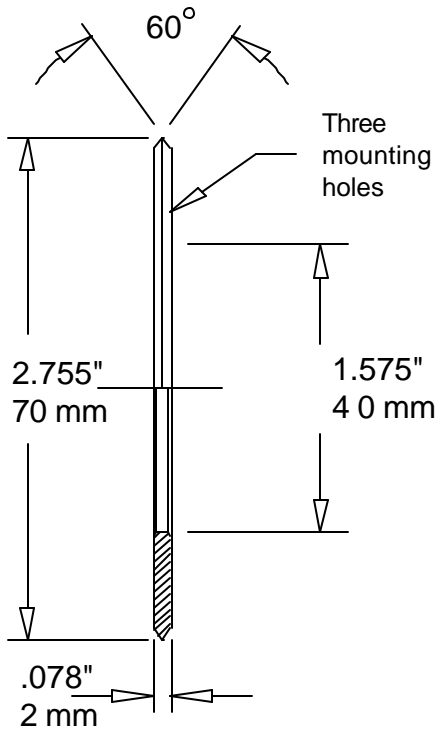

### GOEBEL 70 mm

Part Number	Cuts / inch	Teeth / wheel
16290-0	0	0
16290-2	2	17
16290-3	3	26
16290-4	4	35
16290-5	5	43
16290-6	6	52
16290-7	7	61
16290-8	8	69
16290-10	10	86
16290-12	12	104
16290-16	16	138

### meaden mini perfs

16290-3010	30	260
16290-4510	45	388
16290-5010	50	432
16290-6610	66	570
16290-7210	72	622
16290-3030	30	260
16290-4530	45	388
16290-5030	50	432
16290-6630	66	570
16290-7230	72	622

No charges for marking

Other ties available at no charge up to .060" wide

Any combination of cuts and ties available on request.

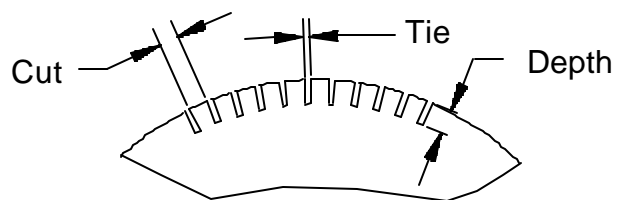

## Pricing Information 17885

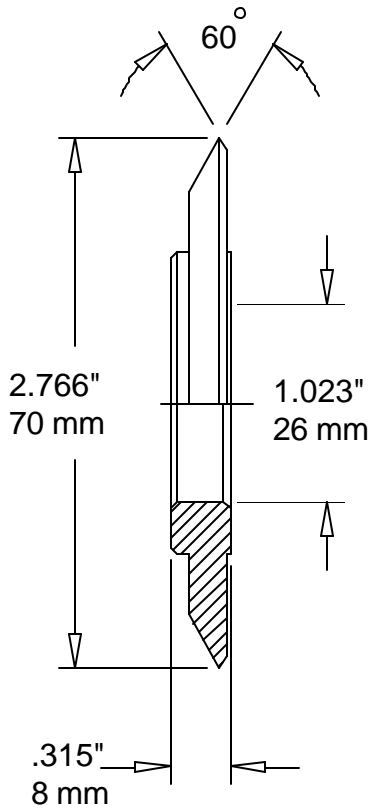

**TAIYO KIKAI**

Part Number	Cuts / inch	Teeth / wheel
17885-0	0	0
17885-2	2	17
17885-3	3	26
17885-4	4	35
17885-5	5	43
17885-6	6	52
17885-7	7	61
17885-8	8	70
17885-10	10	87
17885-12	12	104
17885-16	16	139

### meaden mini perfs

17885-3010	30	260
17885-4510	45	390
17885-5010	50	434
17885-6610	66	572
17885-7210	72	624
17885-3030	30	260
17885-4530	45	390
17885-5030	50	434
17885-6630	66	572
17885-7230	72	624

No charges for marking

Other ties available at no charge up to .060" wide

Any combination of cuts and ties available on request.

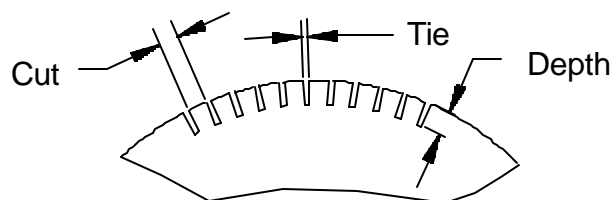

**meaden**

## Pricing Information

## 31511

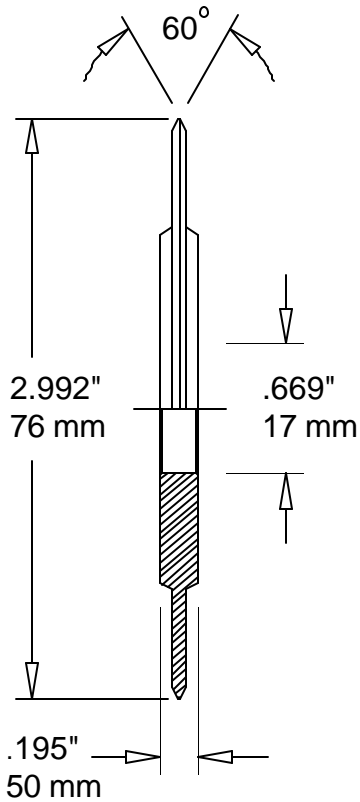

### IMPORTED DOVETAIL HOLDER

bearing 31907  
\$8.00 each

Part Number	Cuts / inch	Teeth / wheel
31511-0	0	0
31511-2	2	19
31511-3	3	28
31511-4	4	38
31511-5	5	47
31511-6	6	56
31511-7	7	66
31511-8	8	75
31511-10	10	94
31511-12	12	113
31511-16	16	150

### meaden mini perfs

31511-3010	30	282
31511-4510	45	423
31511-5010	50	470
31511-6610	66	620
31511-7210	72	677
31511-3030	50	282
31511-4530	45	426
31511-5030	50	470
31511-6630	66	620
31511-7230	72	677

No charges for marking

Other ties available at no charge up to .060" wide  
Any combination of cuts and ties available on request.

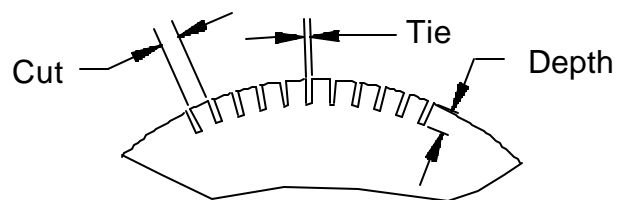

## Pricing Information 14926

**sharp=30255**

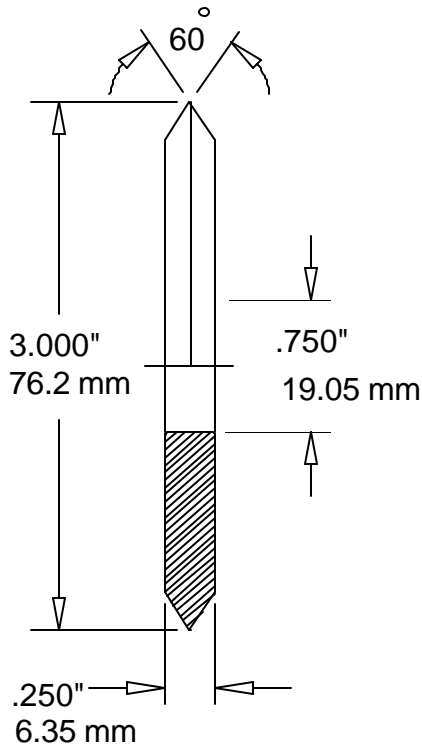

**ASHTON  
SANDEN  
RDP-MARATHON**

Part Number	Cuts /inch	Teeth /wheel
14926-0	0	0
14926-2	2	19
14926-3	3	28
14926-4	4	38
14926-5	5	47
14926-6	6	57
14926-7	7	66
14926-8	8	75
14926-10	10	94
14926-12	12	113
14926-16	16	151

**meaden mini perfs**

14926-3010	30	284
14926-4510	45	424
14926-5010	50	470
14926-6610	66	622
14926-7210	72	678
14926-3030	30	284
14926-4530	45	424
14926-5030	50	470
14926-6630	66	622
14926-7230	72	678

No charges for marking

Other ties available at no charge up to .060" wide

Any combination of cuts and ties available on request.

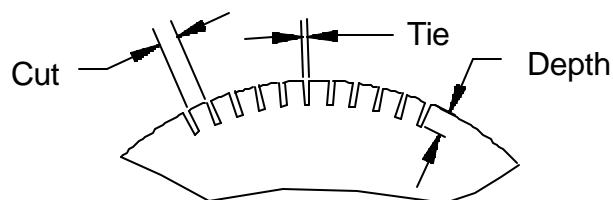

**meaden**

## Pricing Information 20370

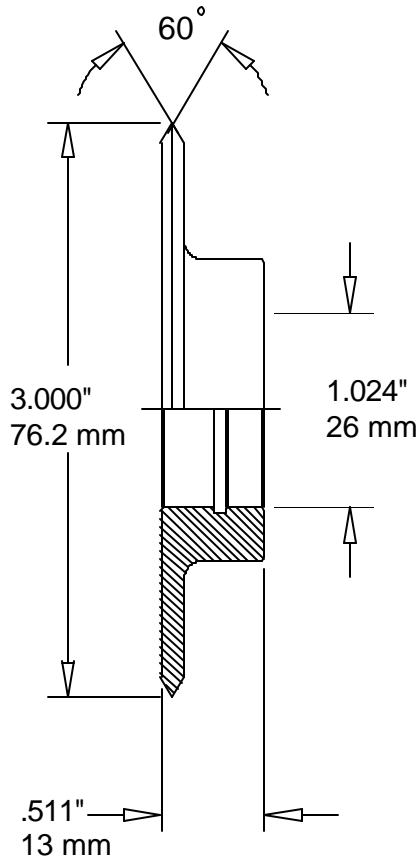

**MULLER MARTINI**

Part Number	Cuts /inch	Teeth /wheel
20370-0	0	0
20370-2	2	19
20370-3	3	28
20370-4	4	38
20370-5	5	47
20370-6	6	57
20370-7	7	66
20370-8	8	75
20370-10	10	94
20370-12	12	113
20370-16	16	151

**meaden mini perfs**

20370-3010	30	284
20370-4510	45	424
20370-5010	50	470
20370-6610	66	622
20370-7210	72	678
20370-3030	30	284
20370-4530	45	424
20370-5030	50	470
20370-6630	66	622
20370-7230	72	678

No charges for marking

Other ties available at no charge up to .060" wide

Any combination of cuts and ties available on request.

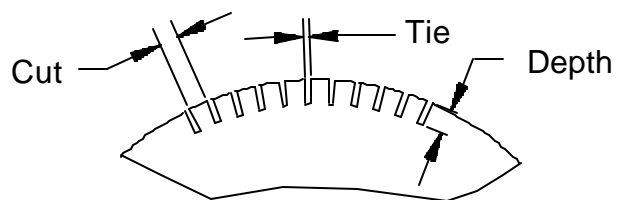

**meaden**

## Pricing Information 18285

sharp=21157

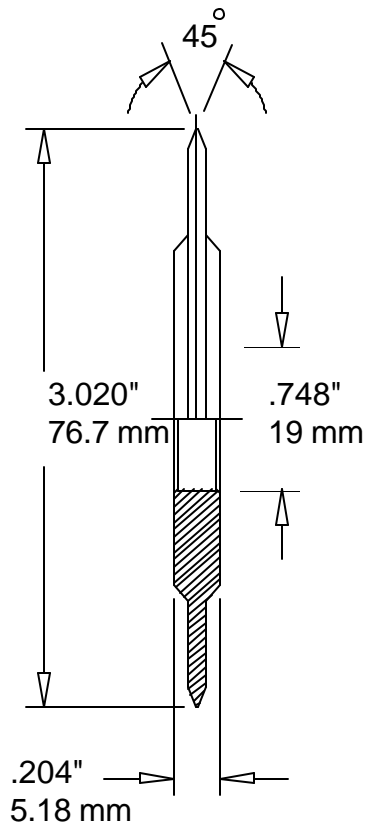

Part Number	Cuts / inch	Teeth / wheel
18285-0	0	0
18285-2	2	19
18285-3	3	29
18285-4	4	38
18285-5	5	48
18285-6	6	57
18285-7	7	67
18285-8	8	76
18285-10	10	95
18285-12	12	114
18285-16	16	152

### meaden mini perfs

18285-3010	30	284
18285-4510	45	426
18285-5010	50	474
18285-6610	66	626
18285-7210	72	684
18285-3030	30	284
18285-4530	45	426
18285-5030	50	474
18285-6630	66	626
18285-7230	72	684

**GRAPHA/MULLER  
GIEBELER  
ROTATEK**

No charges for marking

Other ties available at no charge up to .060" wide

Any combination of cuts and ties available on request.

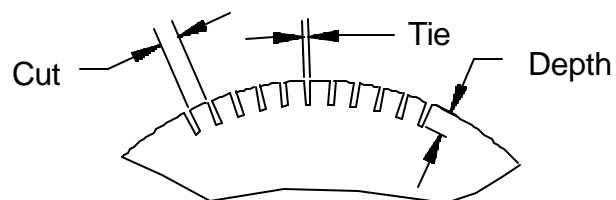

**meaden**

## Pricing Information 19721

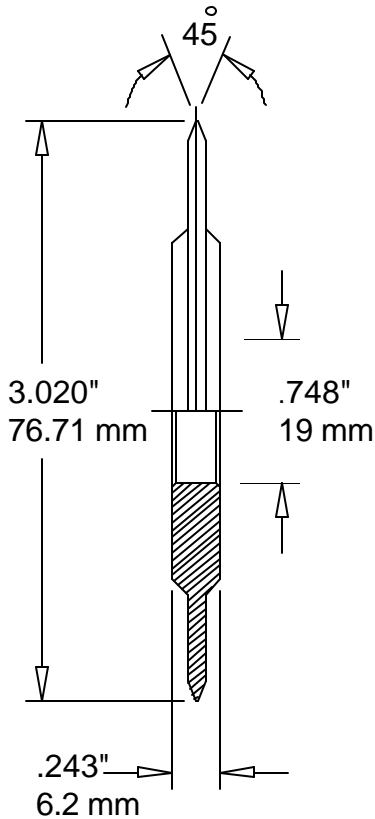

**DUSENBERY  
229002**

**bearing C-96-PP**

Part Number	Cuts / inch	Teeth / wheel
19721-0	0	0
19721-2	2	19
19721-3	3	29
19721-4	4	38
19721-5	5	48
19721-6	6	57
19721-7	7	67
19721-8	8	76
19721-10	10	95
19721-12	12	114
19721-16	16	152

**meaden mini perfs**

19721-3010	30	284
19721-4510	45	426
19721-5010	50	474
19721-6610	66	626
19721-7210	72	684
19721-3030	30	284
19721-4530	45	426
19721-5030	50	474
19721-6630	66	626
19721-7230	72	684

No charges for marking

Other ties available at no charge up to .060" wide

Any combination of cuts and ties available on request.

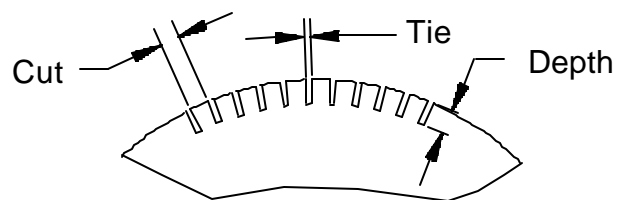

**meaden**

## Pricing Information 14930

**sharp=21161**

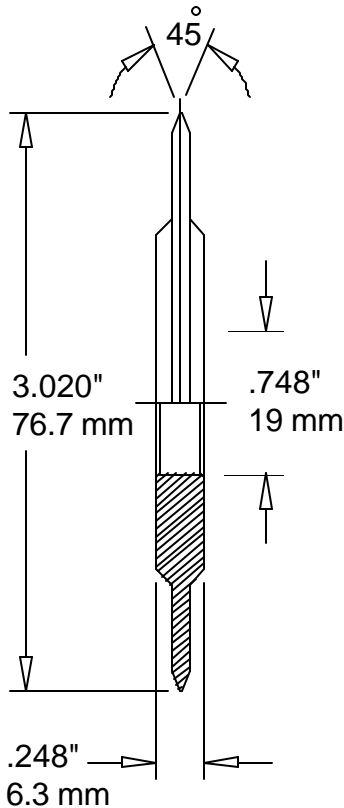

Part Number	Cuts / inch	Teeth / wheel
14930-0	0	0
14930-2	2	19
14930-3	3	29
14930-4	4	38
14930-5	5	48
14930-6	6	57
14930-7	7	67
14930-8	8	76
14930-10	10	95
14930-12	12	114
14930-16	16	152

**meaden mini perfs**

14930-3010	30	284
14930-4510	45	426
14930-5010	50	474
14930-6610	66	626
14930-7210	72	684
14930-3030	30	284
14930-4530	45	426
14930-5030	50	474
14930-6630	66	626
14930-7230	72	684

**CAMERON 428-A  
CODIMAG  
EDELMANN  
GIEBELER  
HAMILTON/STEVENS  
ROTATEK**

**bearing C-96-PP  
\$4.00 each**

No charges for marking  
Other ties available at no charge up to .060" wide  
Any combination of cuts and ties available on request.

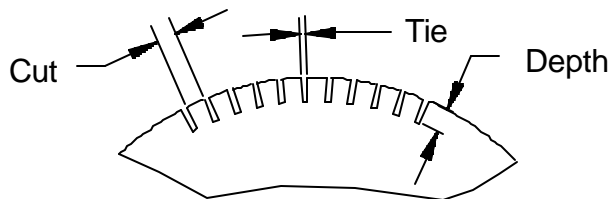

## Pricing Information 14934

### sharp=24934

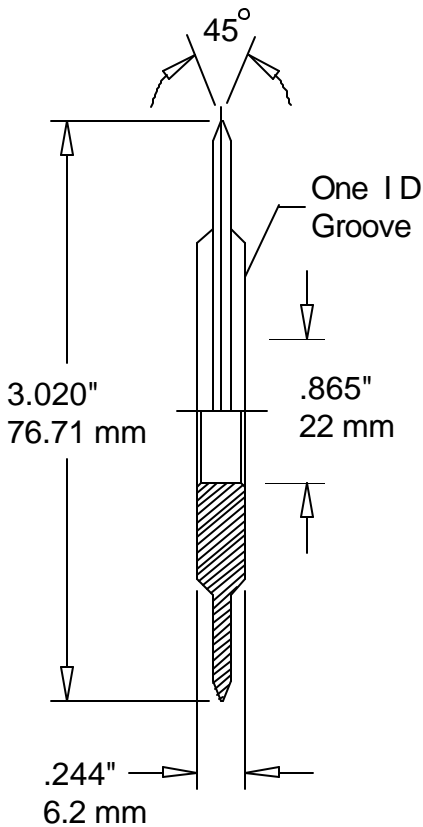

Note: This uses a press fit bearing

### KIDDER

Part Number	Cuts / inch	Teeth / wheel
14934-0	0	0
14934-2	2	19
14934-3	3	29
14934-4	4	38
14934-5	5	48
14934-6	6	57
14934-7	7	67
14934-8	8	76
14934-10	10	95
14934-12	12	114
14934-16	16	152

### meaden mini perfs

14934-3010	30	284
14934-4510	45	426
14934-5010	50	474
14934-6610	66	626
14934-7210	72	684
14934-3030	30	284
14934-4530	45	426
14934-5030	50	474
14934-6630	66	626
14934-7230	72	684

No charges for marking

Other ties available at no charge up to .060" wide  
Any combination of cuts and ties available on request.

bearing X-117  
\$8.00 each

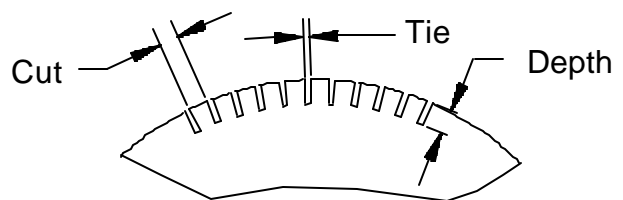

# Pricing Information 14929

**sharp=21154**

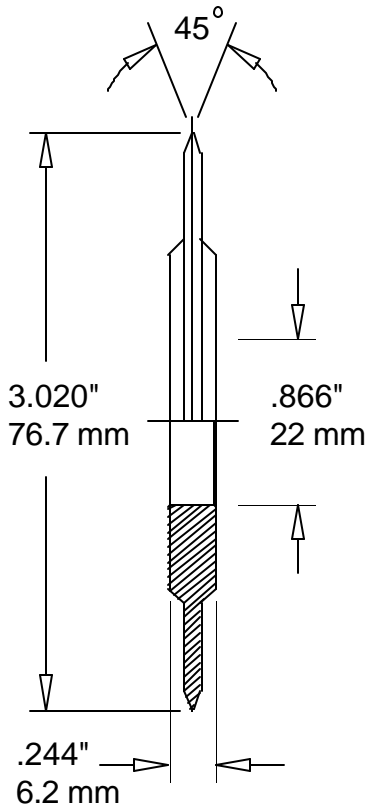

Part Number	Cuts / inch	Teeth / wheel
14929-0	0	0
14929-2	2	19
14929-3	3	29
14929-4	4	38
14929-5	5	48
14929-6	6	57
14929-7	7	67
14929-8	8	76
14929-10	10	95
14929-12	12	114
14929-16	16	152

**meaden mini perfs**

14929-3010	30	284
14929-4510	45	426
14929-5010	50	474
14929-6610	66	626
14929-7210	72	684
14929-3030	30	284
14929-4530	45	426
14929-5030	50	474
14929-6630	66	626
14929-7230	72	684

30 Degrees use 30382  
 60 Degrees use 30879  
 90 Degrees use 15361

**CAMERON 793-A  
 HAMILTON/  
 STEVENS**

**bearing X-117  
 \$8.00 each**

No charges for marking  
 Other ties available at no charge up to .060" wide  
 Any combination of cuts and ties available on request.

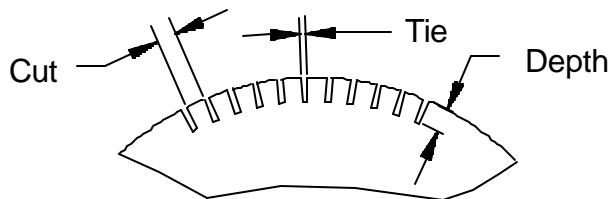

## Pricing Information 14933

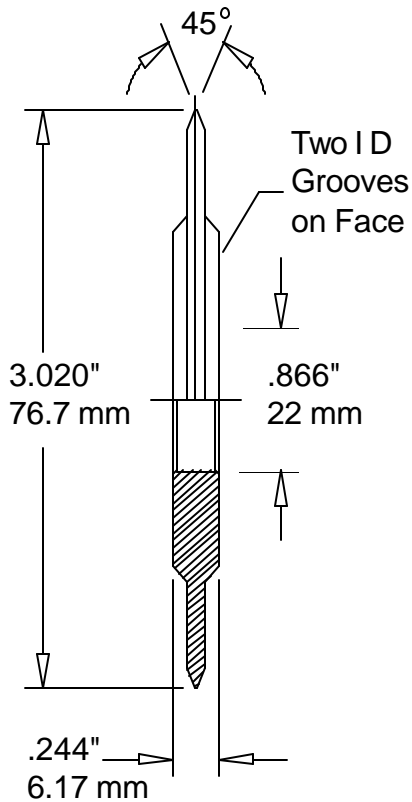

Part Number	Cuts / inch	Teeth / wheel
14933-0	0	0
14933-2	2	19
14933-3	3	29
14933-4	4	38
14933-5	5	48
14933-6	6	57
14933-7	7	67
14933-8	8	76
14933-10	10	95
14933-12	12	114
14933-16	16	152

### meaden mini perfs

14933-3010	30	284
14933-4510	45	426
14933-5010	50	474
14933-6610	66	626
14933-7210	72	684
14933-3030	30	284
14933-4530	45	426
14933-5030	50	474
14933-6630	66	626
14933-7230	72	684

**Note: This wheel is 57- 59 Rc to prevent anvil damage**

**HAMILTON**

**bearing X-117  
\$8.00 each**

No charges for marking

Other ties available at no charge up to .060" wide  
Any combination of cuts and ties available on request.

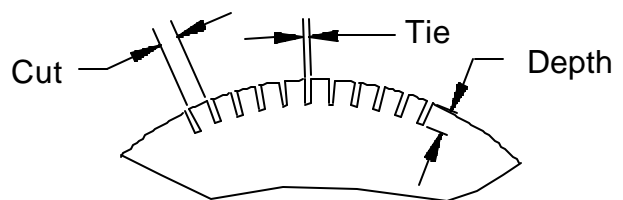

**meaden**

# Pricing Information 19457

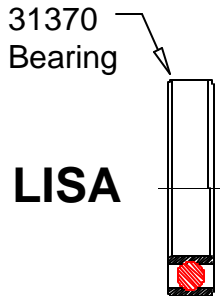
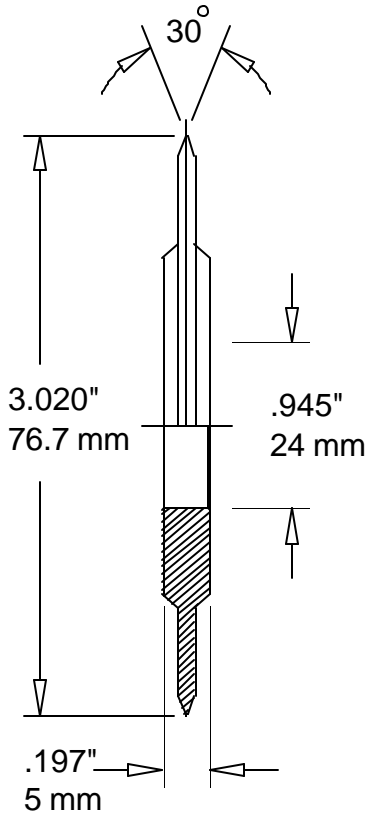

**bearing 31370**

Part Number	Cuts / inch	Teeth / wheel
19457-0	0	0
19457-2	2	19
19457-3	3	29
19457-4	4	38
19457-5	5	48
19457-6	6	57
19457-7	7	67
19457-8	8	76
19457-10	10	95
19457-12	12	114
19457-16	16	152

**meaden mini perfs**

19457-3010	30	284
19457-4510	45	426
19457-5010	50	474
19457-6610	66	626
19457-7210	72	684
19457-3030	30	284
19457-4530	45	426
19457-5030	50	474
19457-6630	66	626
19457-7230	72	684

No charges for marking

Other ties available at no charge up to .060" wide

Any combination of cuts and ties available on request.

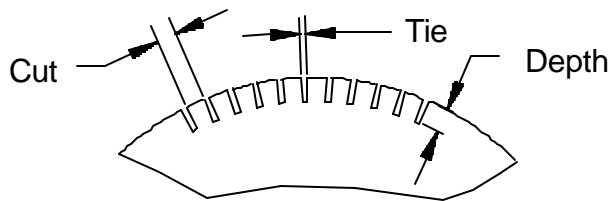

## Pricing Information 16893

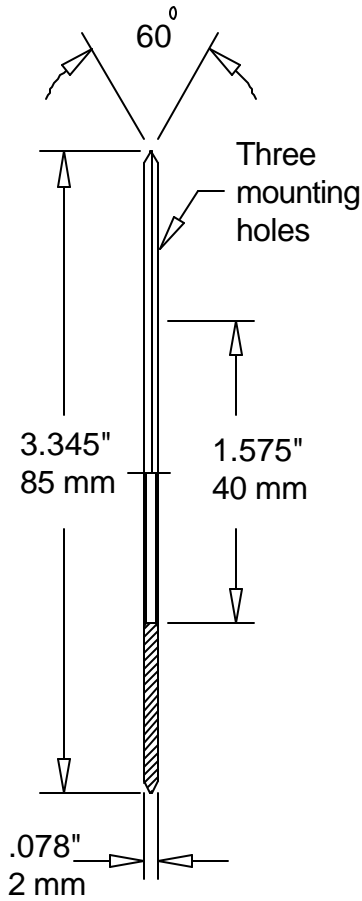

### GOEBEL 85 mm

Part Number	Cuts / inch	Teeth / wheel
16893-0	0	0
16893-2	2	21
16893-3	3	32
16893-4	4	42
16893-5	5	53
16893-6	6	63
16893-7	7	74
16893-8	8	84
16893-10	10	105
16893-12	12	126
16893-16	16	168

### meaden mini perfs

16893-3010	30	314
16893-4510	45	472
16893-5010	50	524
16893-6610	66	692
16893-7210	72	756
16893-3030	30	314
16893-4530	45	472
16893-5030	50	524
16893-6630	66	692
16893-7230	72	756

No charges for marking

Other ties available at no charge up to .060" wide

Any combination of cuts and ties available on request.

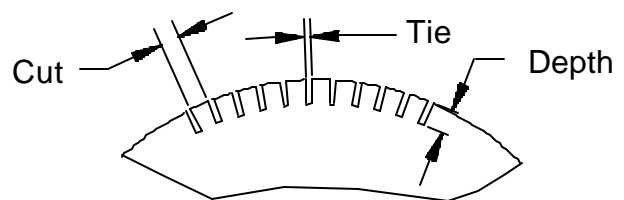

# Pricing Information 31531

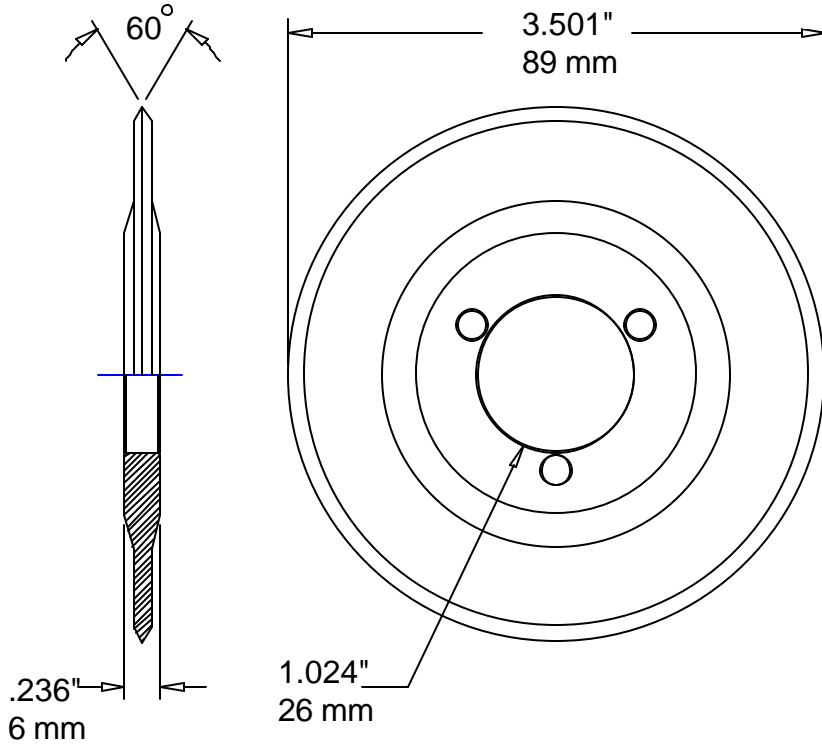

**11" Circumference**  
 Special repeat patterns  
 available on request

## MULLER MARTINI

Part Number	Cuts / inch	Teeth / wheel
31531-0	0	0
31531-2	2	22
31531-3	3	33
31531-4	4	44
31631-5	5	55
31531-6	6	66
31531-7	7	77
31531-8	8	88
31531-10	10	110
31531-12	12	132
31531-16	16	176

**meaden mini perfs**

31531-3010	30	328
31531-4510	45	496
31531-5010	50	550
31531-6610	66	726
31531-7210	72	792
31531-3030	30	328
31531-4530	45	496
31531-5030	50	550
31531-6630	66	726
31531-7230	72	792

No charges for marking  
 Other ties available at no charge up to .060" wide  
 Any combination of cuts and ties available on request.

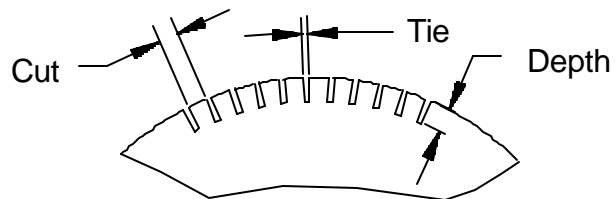

## Pricing Information 20181

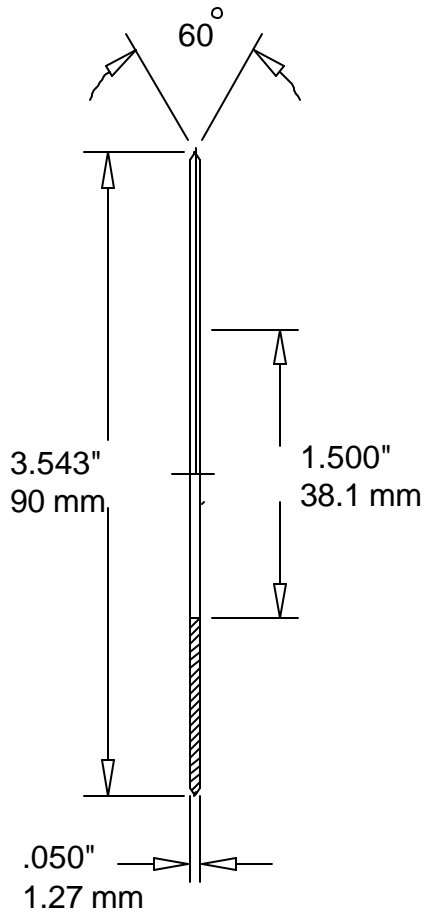

### SCHOBER

Part Number	Cuts / inch	Teeth / wheel
20181-0	0	0
20181-2	2	22
20181-3	3	33
20181-4	4	44
20181-5	5	56
20181-6	6	67
20181-7	7	78
20181-8	8	89
20181-10	10	111
20181-12	12	134
20181-16	16	178

### meaden mini perfs

20181-3010	30	332
20181-4510	45	500
20181-5010	50	556
20181-6610	66	734
20181-7210	72	802
20181-3030	30	332
20181-4530	45	500
20181-5030	50	556
20181-6630	66	734
20181-7230	72	802

No charges for marking

Other ties available at no charge up to .060" wide

Any combination of cuts and ties available on request.

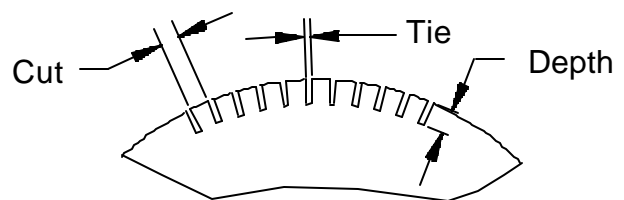

Pricing Information 31346

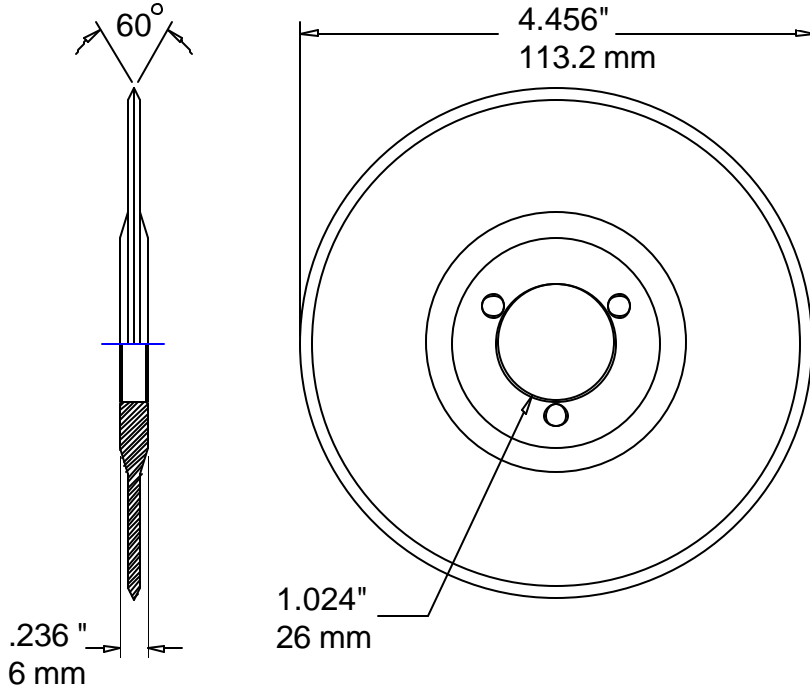

**14" Circumference**  
 Special repeat patterns  
 available on request  
**MULLER MARTINI**

Part Number	Cuts / inch	Teeth / wheel
31346-0	0	0
31346-2	2	28
31346-3	3	42
31346-4	4	56
31346-5	5	70
31346-6	6	84
31346-7	7	98
31346-8	8	112
31346-10	10	140
31346-12	12	168
31346-16	16	224

**meaden mini perfs**

31346-3010	30	420
31346-4510	45	630
31346-5010	50	700
31346-6610	66	924
31346-7210	72	1008
31346-3030	30	420
31346-4530	45	630
31346-5030	50	700
31346-6630	66	924
31346-7230	72	1008

No charges for marking  
 Other ties available at no charge up to .060" wide  
 Any combination of cuts and ties available on request.

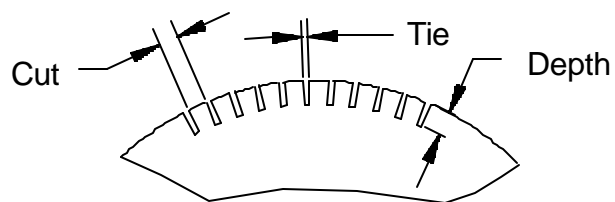

## Pricing Information 31530

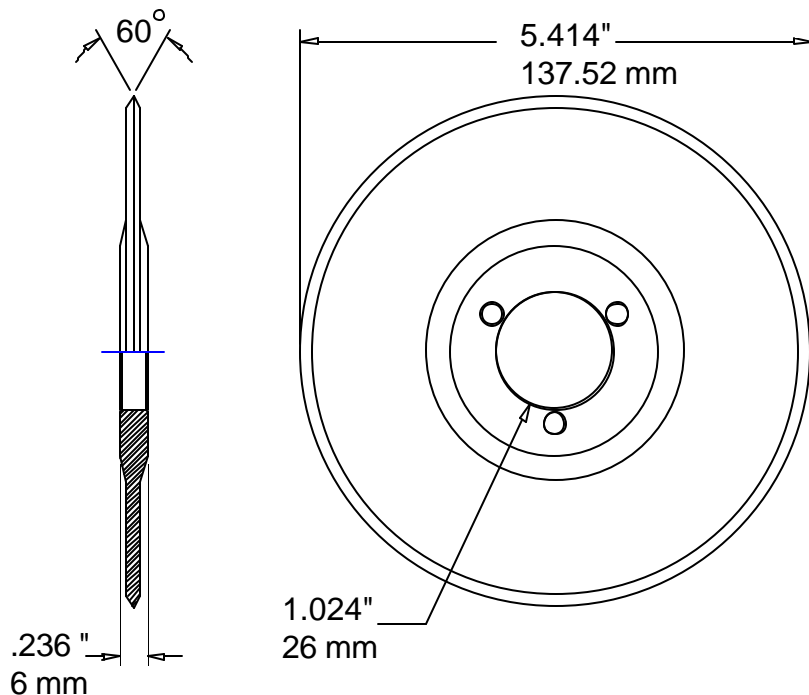

**17" Circumference**

Special repeat patterns  
available on request

**MULLER MARTINI**

Part Number	Cuts / inch	Teeth / wheel
31530-0	0	0
31530-2	2	34
31530-3	3	51
31530-4	4	68
31530-5	5	85
31530-6	6	102
31530-7	7	98
31530-8	8	119
31530-10	10	170
31530-12	12	204
31530-16	16	272

**meaden mini perfs**

31530-3010	30	510
31530-4510	45	765
31530-5010	50	850
31530-6610	66	1122
31530-7210	72	1224
31530-3030	30	510
31530-4530	45	765
31530-5030	50	850
31530-6630	66	1122
31530-7230	72	1224

No charges for marking

Other ties available at no charge up to .060" wide

Any combination of cuts and ties available on request.

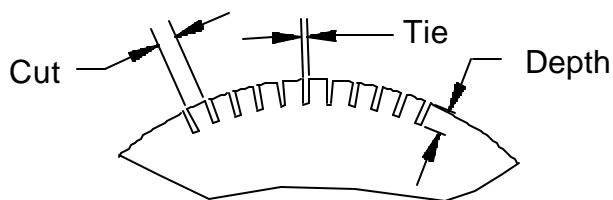

**meaden**

# CORE CUTTER BLADES

## Pricing Information

## CORE CUTTERS

### APPLETON

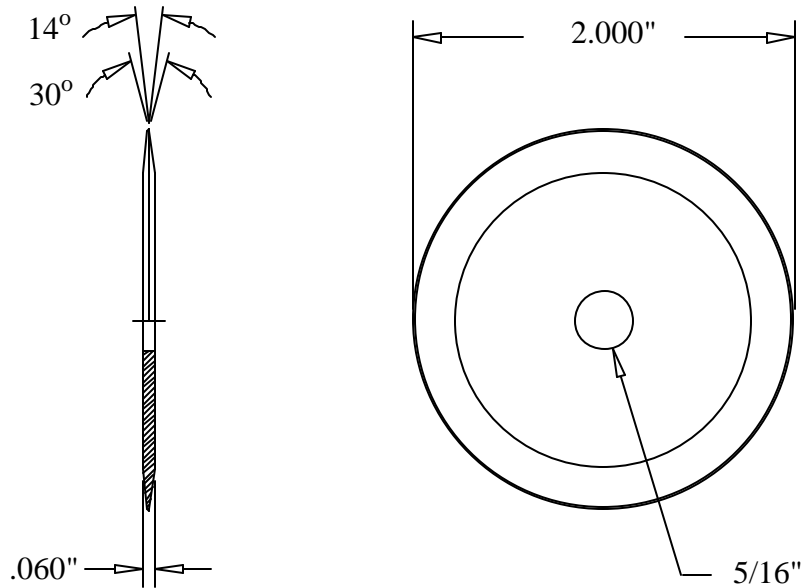

#### Price List Appleton Core Cutters

Part Number	Description
31908	Standard Steel
31918	Long Life Stainless Steel

CORE-TECH

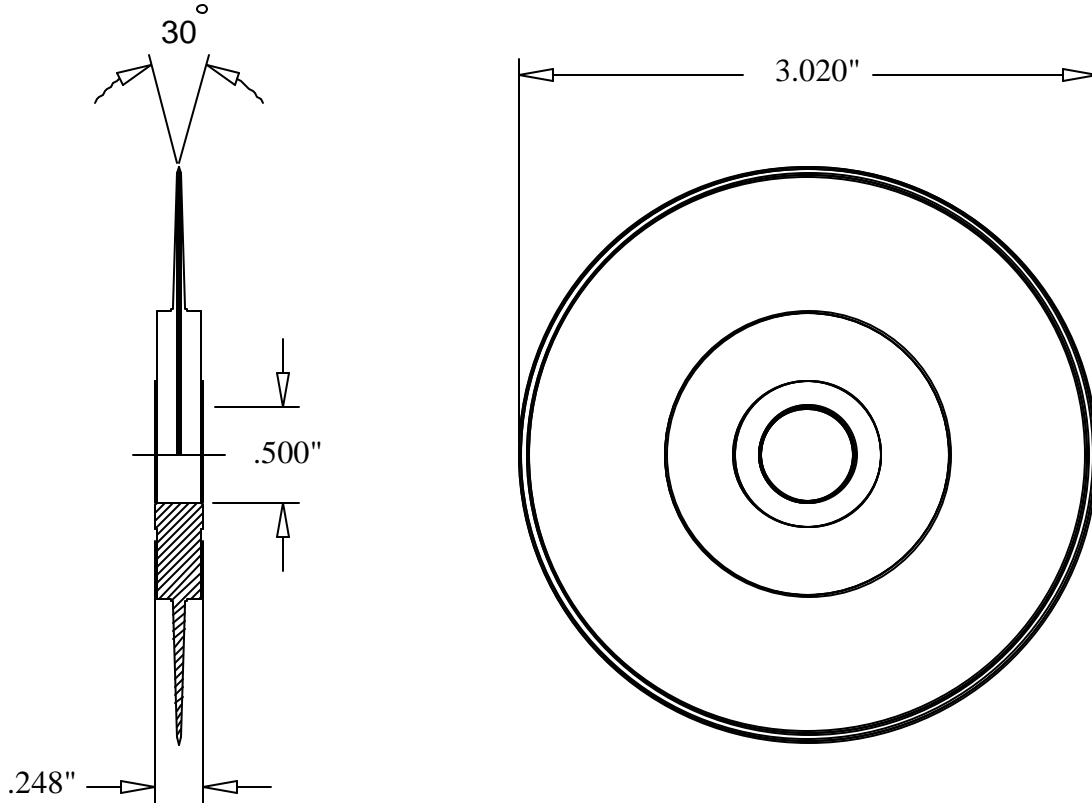

#31339

# TRIMMER BLADES

## Pricing Information

## ARPECO

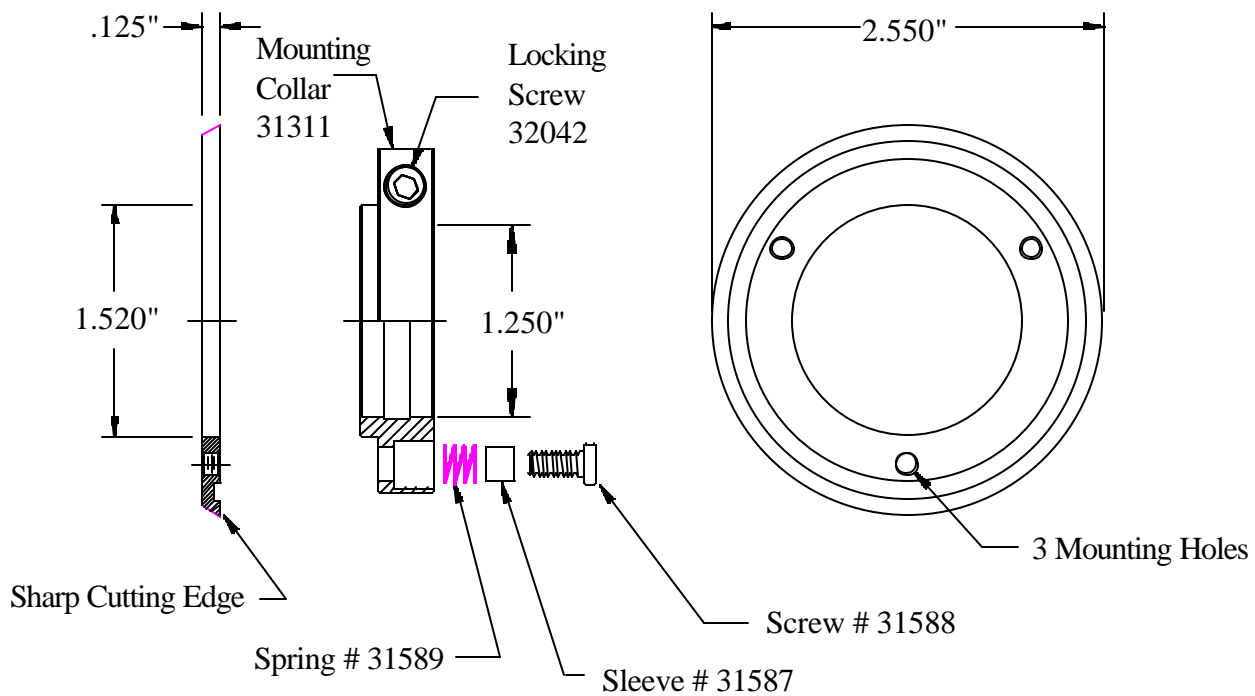

### Lower Knife Assembly

Part Number	Description
31880	Complete Lower Knife Assembly Includes 18420 Lower Knife
18420	Lower Knife ( Beveled )
31311	Mounting Collar Only
31588	Screw
31587	Sleeve
31589	Spring
32042	Locking Screw

## Pricing Information

## ARPECO

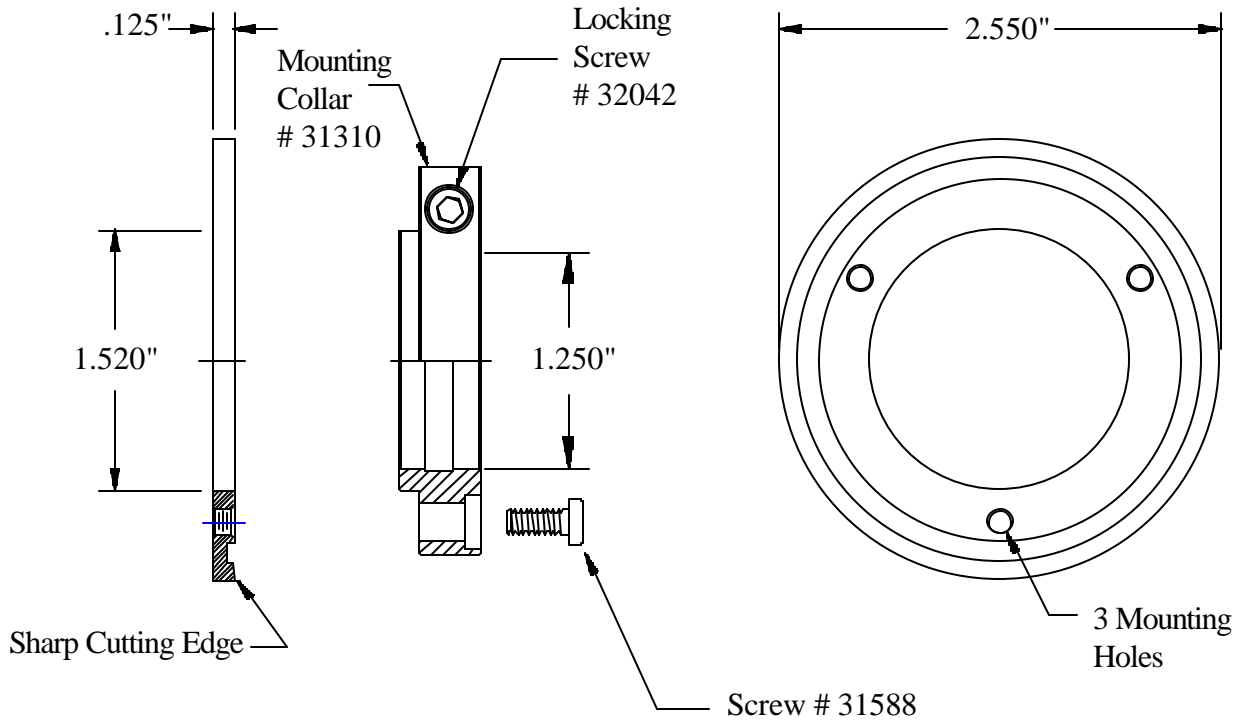

### Top Fixed Knife Assembly

Part Number	Description
31881	Complete Upper Knife Assembly Includes 18801 Upper Knife
18801	Upper Knife
31310	Mounting Collar
31588	Screw
32042	Locking Screw

# Pricing Information

# SHEAR KNIVES

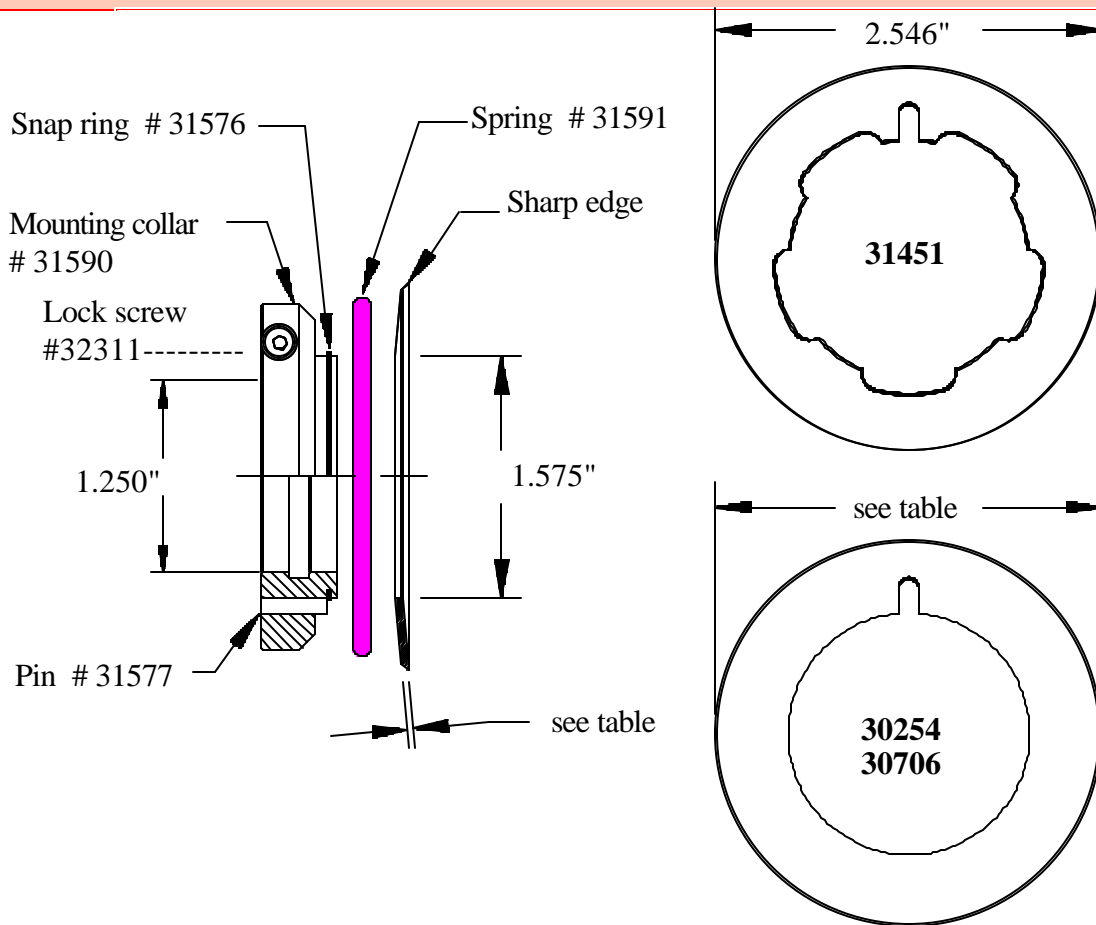

Part Number	Description	Dimensions
30254	Shear Slitter	2.441"x1.575"x.048"
30706	Shear Slitter	2.440"x1.575"x.039"
31451	Shear Slitter	2.546"x1.575"x.048"
31904	Complete Holder No Blade	
31590	Mounting Collar Only	
31576	Snap Ring	
31577	Pin	
31591	Spring	
32311	Lock Screw	

## Pricing Information    Bowe Letter Trimmer

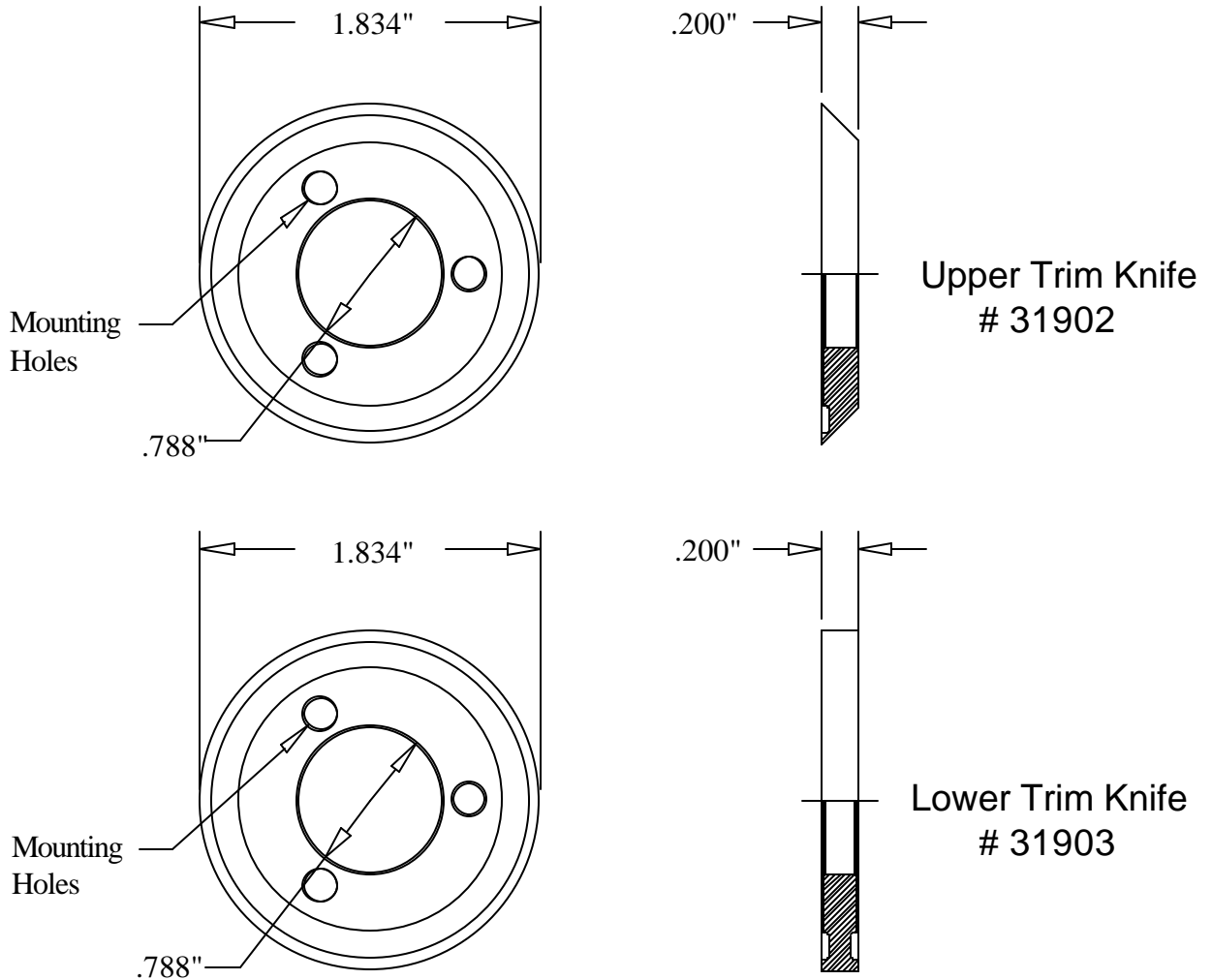

### Price List Bowe Letter Trimmer

Part Number	Description
31902	Upper Trim Knife
31903	Lower Trim Knife

# DISHED BLADES

## Pricing Information

## Dished Slitter Knives

Dished Slitter Knife  
PART #15379

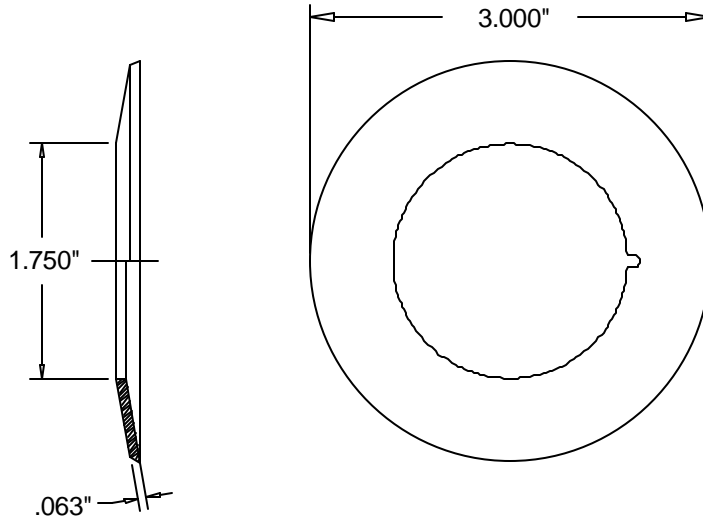

Dished Slitter Knife  
PART #30601

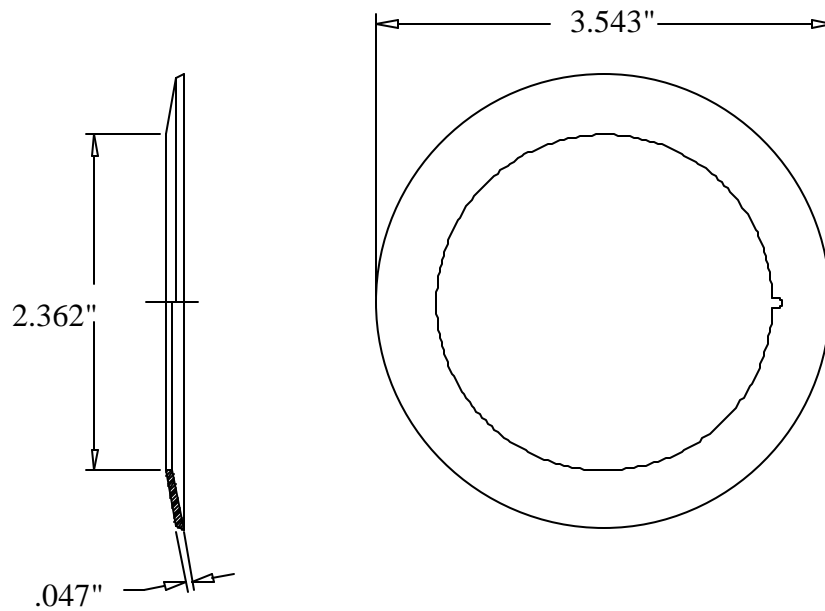

# COLLATOR BLADES

Collator

TRIM KNIFE

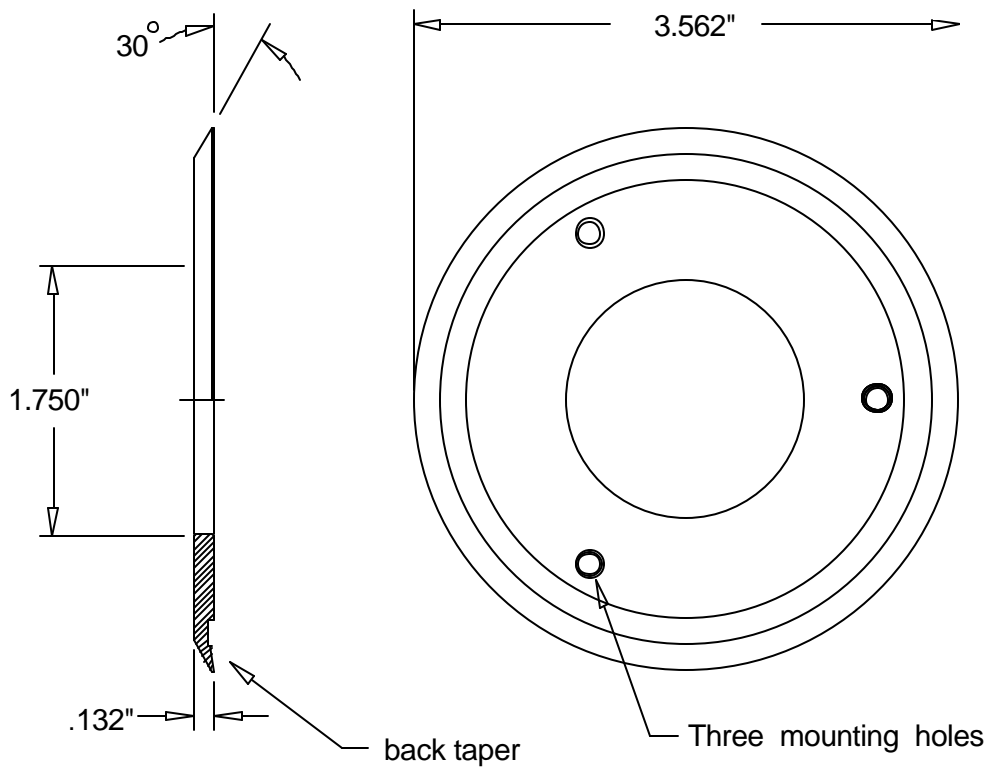

**PART #15280 1.5 degree back taper**

**PART #31737 3.0 degree back taper**

B. BUNCH  
 DIDDE  
 FORM FLO  
 HARRIS / SCHRIBER  
 ROTATEK

Collator

HAMILTON UPPER TRIM KNIFE

**PART #15281  
TOP KNIFE**

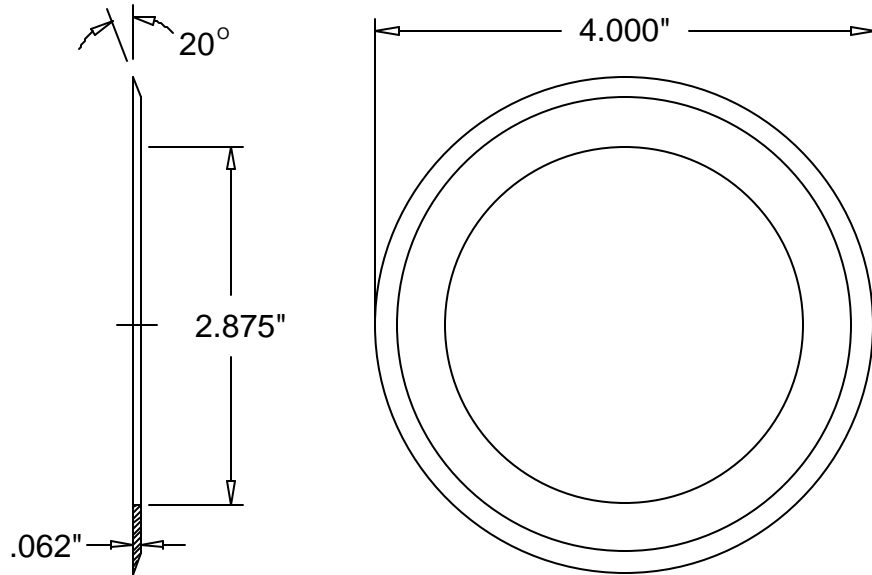

Collator

HAMILTON LOWER TRIM KNIFE

**PART #15282  
BOTTOM  
KNIFE**

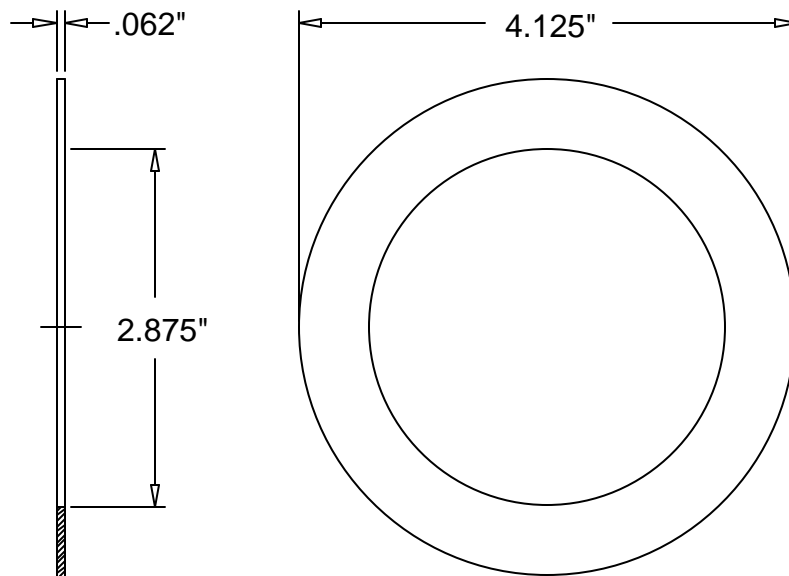

Collator

TRIM KNIFE

**WESTERN GEAR**

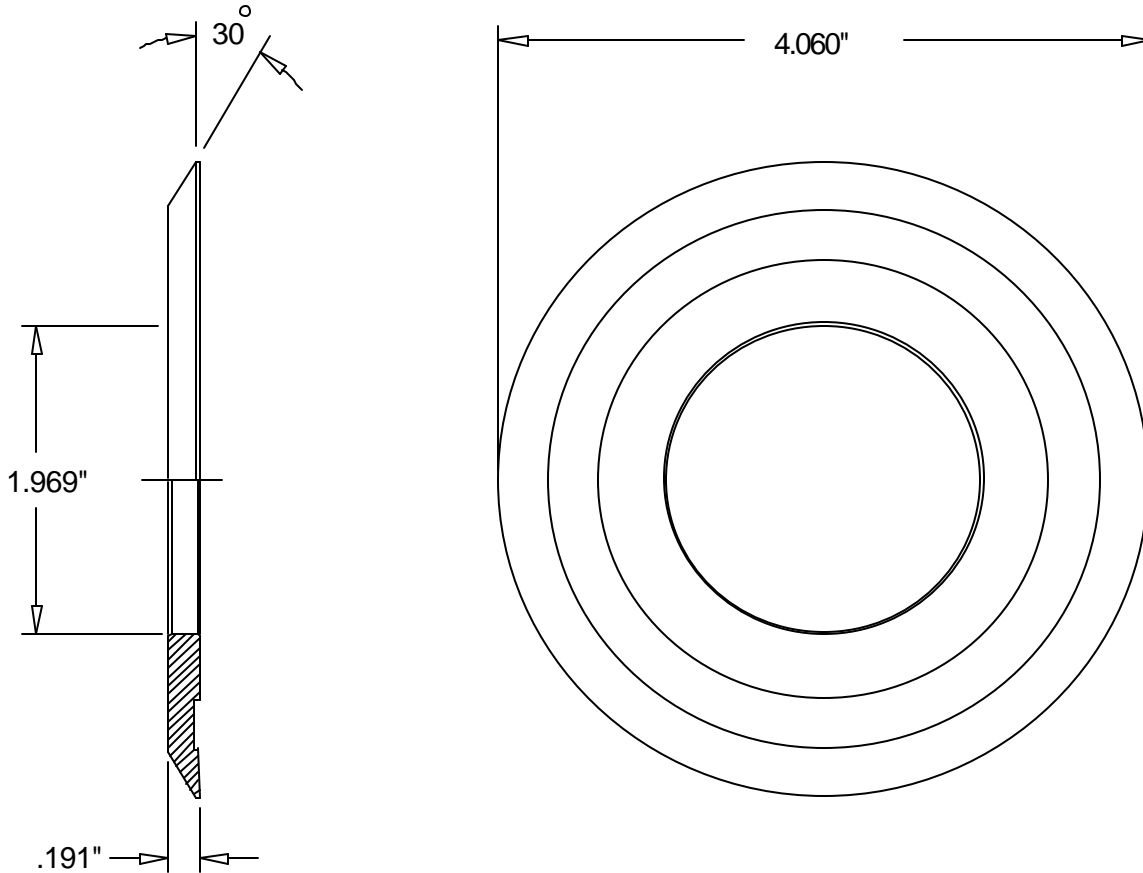

**Top and bottom knives are the same**  
**Part #15146**

Collator

PERFORATOR WHEEL

HAMILTON

Part Number 14932

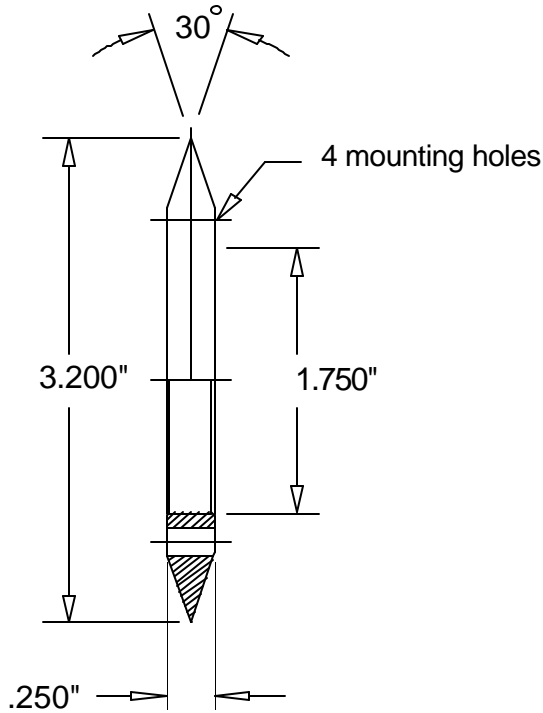

Part Number	Cuts /inch	Teeth /wheel
14932-0	0	0
14932-2	2	20
14932-3	3	30
14932-4	4	40
14932-5	5	50
14932-6	6	60
14932-7	7	70
14932-8	8	80
14932-10	10	101
14932-12	12	121
14932-16	16	161

Note: Sold in matched halves

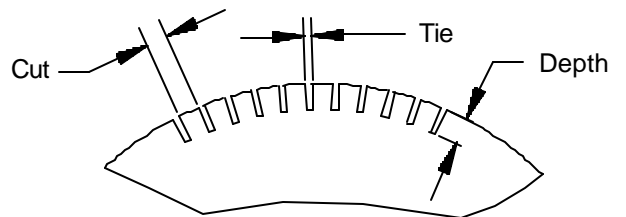

## Collator

## PERFORATOR WHEEL

## WESTERN GEAR

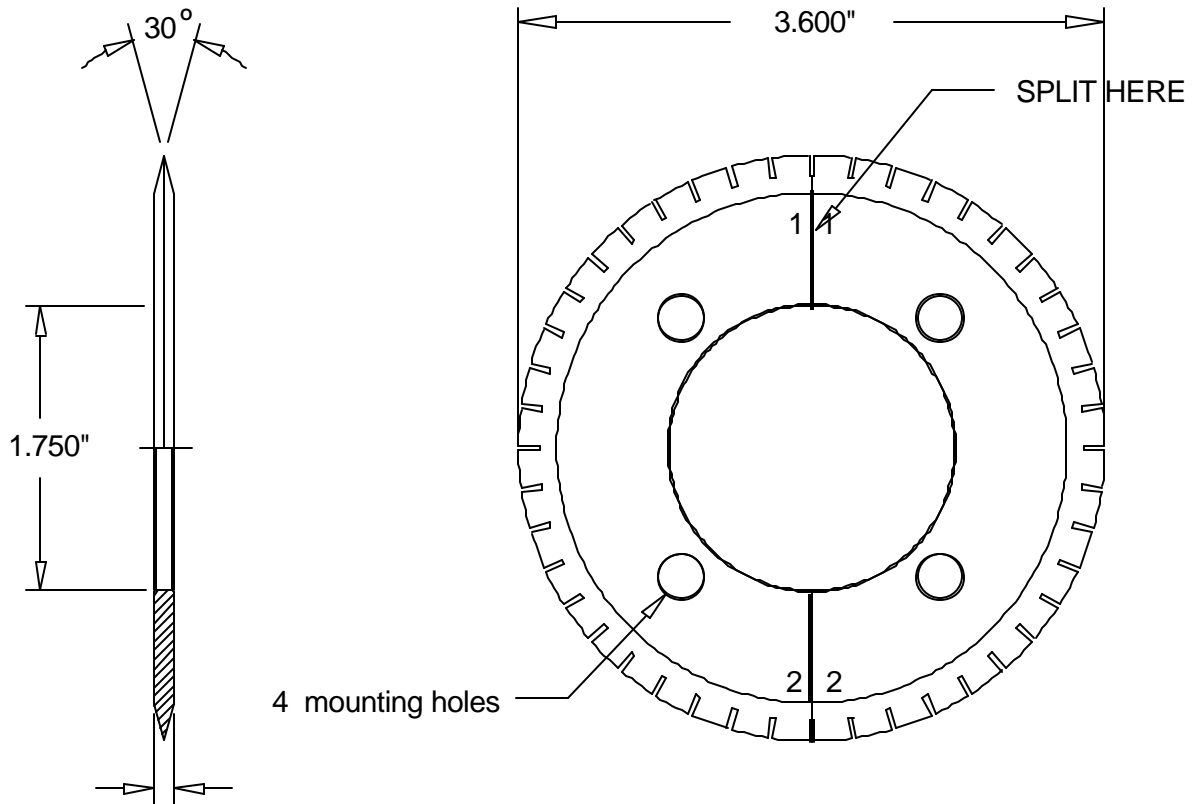

Note: Sold in matched halves

### Part #15199